

Home Hub

Installation and Operation Manual

Revision	Description	Date
00	Initial	2024/3/22

Table of Contents

1	IMPORTANT SAFETY INFORMATION	5
1.1	Safety Symbols And Terminology Definitions	7
1.2	Safety Instructions	9
2	INTRODUCTION	12
2.1	System	12
2.2	Data Evaluation And Communication	15
2.3	Technical Structure Of GM Energy Home Hub	15
2.4	Equipment Overview	16
2.5	GM Energy Home Hub Label And Dimensions	18
3	INSTALLATION	20
3.1	Visual Inspection	22
3.2	Installation Location	24
3.3	Mounting The GM Energy Home Hub	24
4	ELECTRICAL CONNECTIONS	30
4.1	Important Safety Information	30
4.2	Utility AC Voltage	33
4.3	AC Circuit Breaker Requirements	35
4.4	Equipment Grounding Conductor (EGC)	35
4.5	Main Bonding Jumper(Optional)	36
4.6	GM Energy Home Hub Connections	37
4.6.1	Important Safety Information	37
4.6.2	Installation Requirements	40
4.6.3	GM Energy Home Hub Conduit Plugs	41
4.6.4	Installed As Service Equipment (Optional)	42
4.6.5	Breaker Selection	44
4.6.6	Installing Raceways And Conductors	46
4.6.7	Wiring GM Energy Home Hub	47
4.6.8	Communication Wiring	57
4.6.9	Installation of Optional Meter2	58
4.6.10	Final Inspection	62
5	PCS CRD	63
6	COMMISSIONING THE V2H SYSTEM	67
6.1	Commissioning App	68
7	COMMISSIONING THE SYSTEM	68
7.1	Buzzer Indication	68
8	PRODUCTION INFORMATION	69
9	REPAIR	69
10	DECOMMISSIONING, TRANSPORT, STORAGE, DISPOSAL	70
10.1	Decommissioning	71
10.2	Packaging	71
10.3	Transport	71

10.4	Storage	71
10.5	Disposal	71
11	CERTIFICATE AND TECHNICAL DATA	72
11.1	Certificate	72
11.2	Technical Data	72
11.3	FCC Compliance Information	73
11.4	Canada Compliance Information	74
12	LIMITED WARRANTY EXCLUSIONS	74
13	APPENDIX	74
14	GLOSSARY	74

IMPORTANT SAFETY INSTRUCTIONS

SAVE THESE INSTRUCTIONS

1 IMPORTANT SAFETY INFORMATION

This manual contains important instructions for GM Energy Home Hub that should be followed during installation, operation and maintenance of the GM Energy Home Hub. Note throughout this document the GM Energy Home Hub may be referred to as the Home Hub.

Home Hub is designed and tested to meet all applicable North American and International safety standards. However, like all electrical and electronic equipment, safety precautions must be observed and followed during installation and operation of the Home Hub to reduce the risk of personal injury and to ensure a safe installation.

Installation, commissioning, service and maintenance of Home Hub must only be performed by Qualified Personnel that are licensed and/or satisfied state and local jurisdiction regulations.

Before starting installation or commissioning of the Home Hub, read through the entire manual and pay special attention to all DANGER! WARNING! CAUTION!, and NOTICE! statements.

All US electrical installations must comply and be in accordance with all the state, local, utility regulations, and National Electrical Code ANSI/NFPA 70.

For installations in Canada, please ensure these are done in accordance with applicable Canadian standards. And in Canada, Home Hub can not be applied as service equipment.

Ce manuel contient des instructions importantes pour le GM Energy Home Hub qui doivent être suivies lors de l'installation, du fonctionnement et de l'entretien du GM Energy Home Hub. Remarque : dans ce document, le GM Energy Home Hub est désigné par le terme Home Hub.

Le concentrateur est conçu et testé pour répondre à toutes les normes de sécurité nord-américaines et internationales applicables. Cependant, comme pour tout équipement électrique et électronique, des précautions de sécurité doivent être observées et suivies lors de l'installation et de l'utilisation du concentrateur afin de réduire les risques de blessures et d'assurer une installation sûre.

L'installation, la mise en service, l'entretien et la maintenance de l'onduleur GM Energy ne doivent être effectués que par du Personnel Qualifié, titulaire d'une

licence et/ou satisfaisant aux réglementations nationales et locales.

Avant de commencer l'installation ou la mise en service du Home Hub, lisez l'intégralité du manuel et accordez une attention particulière à tous les DANGER ! AVERTISSEMENT ! ATTENTION ! et AVIS!

Toutes les installations électriques américaines doivent être conformes à l'ensemble des réglementations nationales, locales et des services publics, ainsi qu'au code national de l'électricité (ANSI/NFPA 70).

Pour les installations au Canada, veuillez vous assurer qu'elles sont effectuées conformément aux normes canadiennes applicables. Au Canada, Home Hub ne peut pas être utilisé comme équipement de service.

1.1 Safety Symbols And Terminology Definitions



DANGER!

Indicates a hazardous situation which, if not avoided, will result in death or serious injury.

DANGER!

Indique une situation dangereuse qui, si elle n'est pas évitée, est susceptible de provoquer un décès ou des blessures graves.



WARNING!

Indicates a hazardous situation which, if not avoided, could result in death or serious injury.

AVERTISSEMENT!

Indique une situation dangereuse qui, si elle n'est pas évitée, est susceptible de provoquer un décès ou des blessures graves.



CAUTION!

Indicates a hazardous situation which, if not avoided, could result in minor or moderate injury.

PRUDENCE!

Indique une situation dangereuse qui, si elle n'est pas évitée, est susceptible de provoquer des blessures légères ou de degré moyen.



NOTICE!

Indicates a situation that can result in property damage if not avoided.

AVIS!

Indique une situation susceptible de provoquer des dommages à la propriété, si elle n'est pas évitée.



INFORMATION!

Provided that when known and used will ensure optimal operation of the system.

INFORMATIONS!

La prémisse est que, lorsqu'il est connu et utilisé, le fonctionnement optimal du système sera assuré.



HIGH VOLTAGE WARNING!

Indicates hazardous high voltages are present, which, if not avoided, will result in death or serious injury. Thus, only authorized and trained personnel should install and/or maintain this product.

AVERTISSEMENT HAUTE TENSION!

Indique la présence de hautes tensions présentant un danger susceptibles de provoquer un décès ou des blessures graves si elles ne sont pas évitées. Par conséquent, l'installation et/ou l'entretien de ce produit doivent être entreprises uniquement par un personnel autorisé et formé.



Hot surface

Surface chaude



Equipment Grounding Conductor (EGC)

(EGC) Équipement conducteur de terre



Wait for a prescribed amount of time before engaging in the indicated action.

Patiencez le délai requis avant d'entreprendre l'action indiquée.

1.2 Safety Instructions

The GM Energy Home Hub installation must be performed by Qualified Personnel in accordance with the local and National Electrical Code ANSI/NFPA 70 and OSHA requirements.

- For all service and maintenance, the Home Hub should be returned to an Authorized Service Center.
- Read all of these instructions, cautions, and warnings for the Home Hub and associated documentation.
- Before connecting the Home Hub to the AC distribution grid, approval must be received by the appropriate local utility as required by national and state interconnection regulations, and must be connected only by Qualified Personnel.
- In operation, the Home Hub wiring and connections can have hazardous high voltages and currents present, thus only authorized and Qualified Personnel shall install and/or maintain the Home Hub.
- In some operation instances, Home Hub chassis and heatsink surfaces may become hot.
- The device produce hazardous voltages and currents when exposed to light which can create an electrical shock hazard. For DC circuits use caution to avoid connecting module MOC connections (tool required) from PV arrays until all circuit wiring is spliced and terminated and verify polarity of each circuit string before energizing equipment.



NOTICE!

This manual also includes references on how to connect the GM Energy Inverter and GM Energy Home Hub to DC Solar and Energy Storage. However, the GM Energy Inverter is **ONLY** intended to connect a compatible electric vehicle that is capable of vehicle to home discharge when grid power is not present. Future extensions of this product may allow for solar and energy storage to be connected, but the GM Energy Inverter is not capable of that at this point and any attempt to do so will invalidate the warranty. Please refer to most recent update of this document found at <https://gmenergy.gm.com/for-home/resources-and-support> for further information on any updates to future features.



NOTICE!

This manual also includes references on how to connect solar systems with existing inverter(s) to the Home backup panel. An AC solar system must be connected to the non-backup panel such that solar production does not occur during a power outage. Integration of AC Solar on backup panels may be possible in the future. Please refer to most recent update of this document and the system installation manual found at <https://gmenergy.gm.com/for-home/resources-and-support> for further information on solar integration into the backup panel. Do not rework existing solar system without proper communication with customer and/or the previous solar system installer as existing

warranty may be affected.

L'installation du GM Energy Home Hub doit être effectuée par une Personne Qualifiée, conformément au code électrique local et national ANSI/NFPA 70 et aux exigences de l'OSHA.

- Pour toute opération d'entretien et de maintenance, le Home Hub doit être renvoyé à un centre de service agréé.
- Lisez toutes les instructions, précautions et avertissements concernant le Home Hub et la documentation associée.
- Avant de connecter le Home Hub au réseau de distribution CA, l'approbation doit être reçue par le service public local approprié, comme l'exigent les réglementations nationales et régionales en matière d'interconnexion, et le branchement ne doit être effectué que par du Personnel Qualifié.
- En fonctionnement, le câblage et les connexions du Home Hub peuvent présenter des tensions et des courants élevés dangereux, c'est pourquoi seul un personnel autorisé et qualifié doit installer et/ou entretenir le Home Hub.
- Dans certains cas, le châssis du Home Hub et les surfaces du dissipateur thermique peuvent devenir chauds.
- L'appareil produit des tensions et des courants dangereux lorsqu'il est exposé à la lumière, ce qui peut créer un risque d'électrocution. Pour les circuits à courant continu, il faut veiller à éviter les connexions MOC des modules (outil nécessaire) des panneaux photovoltaïques jusqu'à ce que tous les câbles du circuit soient épluchés et terminés, et vérifier la polarité de chaque chaîne de circuit avant de mettre l'équipement sous tension.



AVIS!

Ce manuel comprend également des références sur la manière de connecter l'onduleur GM Energy et le GM Energy Home Hub à un système solaire à courant continu et à un système de stockage d'énergie. Cependant, l'onduleur GM Energy est **UNIQUEMENT** destiné à connecter un véhicule électrique compatible capable de se décharger du véhicule à la maison lorsque le réseau électrique n'est pas présent. Les futures extensions de ce produit pourront permettre de connecter des systèmes solaires et de stockage d'énergie, mais l'onduleur GM Energy n'en est pas capable pour l'instant et toute tentative en ce sens annulera la garantie. Veuillez vous référer à la dernière mise à jour de ce document à l'adresse <https://gmenergy.gm.com/for-home/resources-and-support> pour plus d'informations sur les mises à jour des futures fonctionnalités.



AVIS!

Ce manuel contient également des références sur la manière de connecter les systèmes solaires avec onduleur(s) existant(s) au panneau de secours de la maison. Un système solaire à courant alternatif doit être raccordé au panneau autre que le panneau de secours, de sorte que la production solaire ne se produise pas pendant une panne de courant. L'intégration d'un système solaire à

courant alternatif sur les panneaux de secours pourrait être possible à l'avenir. Veuillez vous référer à la dernière mise à jour de ce document et au manuel d'installation du système disponible sur le site <https://gmenergy.gm.com/for-home/resources-and-support> pour plus d'informations sur l'intégration du solaire dans le panneau de secours. Ne pas retravailler un système solaire existant sans une communication adéquate avec le client et/ou l'ancien installateur du système solaire, car la garantie existante pourrait être affectée.

2 INTRODUCTION

The GM Energy Home Hub e1.200(GM Energy Home Hub) is a micro-grid interconnect device for the whole home back-up. It can be used to transfer energy between on-grid mode and off-grid mode with its auto grid detection. It is also an intelligent breaker panel with integrated connectivity, monitoring, and control for home loads, solar PV generation, energy storage*, electric vehicle charging equipment, and the utility grid.

2.1 System

In the following system level technical description, the precise functions are explained to the installer, as well as the user, which are required for the installation, operational start-up and handling of the system.

The GM Energy Home Hub is wall-mounted and similar in size, weight, and configuration to traditional electrical panels, allowing it to be installed in place of a typical 120/240VAC breaker panel using standard tools and materials. GM Energy Home Hub installations can be designed to support both DC-coupled energy storage systems (where the solar generation and battery storage systems are managed by a GM Energy Inverter) and AC-coupled systems (where the solar generation and battery storage systems each have their own Inverter).

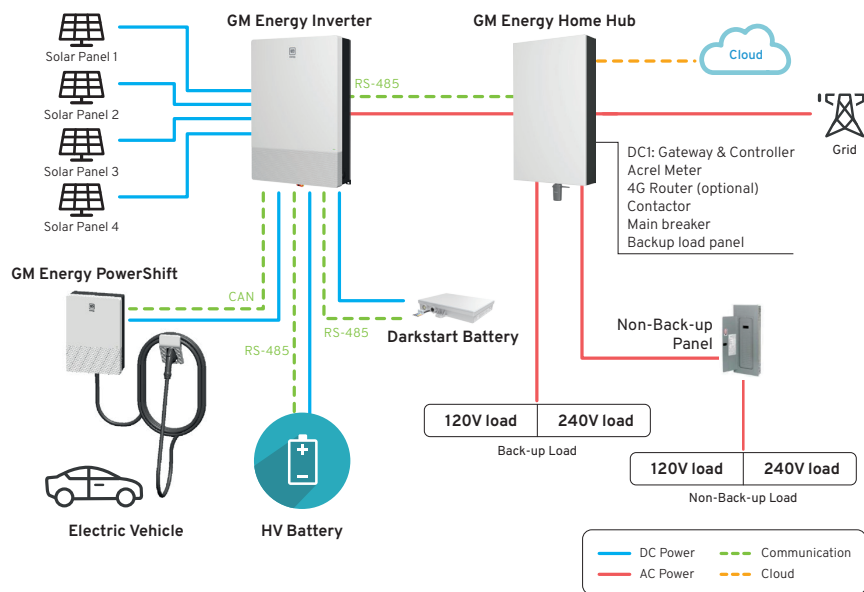

Figure 1: System equipment overview

GM Energy Inverter

The GM Energy Inverter manages PV, HV battery* and compatible electric vehicle battery energy.

PV Panel

The GM Energy Inverter manages PV, HV battery and compatible electric vehicle battery energy.

For DC-couple system, PV panel works in MPPT mode or power reduction mode according to system operational mode. For AC-couple system, there may be no solar module connected to GM Energy Inverter, and the PV power option will be deactivated.

High Voltage Battery

If a high voltage(HV) battery is connected to the GM Energy Inverter, it must be activated before use. This setting can be done in factory test or via App after installation.

HV battery communicates with GM Energy Inverter via RS485 or CAN. And the battery must comply with the specifications of UL 1973.

GM Energy PowerShift

GM Energy PowerShift is connected between compatible electric vehicle and GM Energy Inverter responsible for the charge and discharge management of

the compatible electric vehicle. Throughout this document the GM Energy PowerShift may be referred to Electric Vehicle Supply Equipment(EVSE).

GM Energy Dark Start Battery(DSB)

GM Energy Dark Start Battery is connected to GM Energy Inverter. When the AC grid is lost, the Dark Start Battery supplies power to the control circuit of the GM Energy Inverter and the GM Energy PowerShift.

Rapid Shutdown Device*

The RSD provides an automatic disconnect of residential or small commercial PV systems that are wired into the inverter DC MPPTs, fully compliant with the Rapid Shutdown requirements of NEC Article 690.12.

GM Energy Home Hub

GM Energy Home Hub is a 200A rated micro-grid interconnect device for the whole home or partial home backup. It can serve as the Main Service Panel and can be used to transfer energy between on-grid mode and off-grid mode with its auto grid detection. The number of breakers mounted inside offers more individual power supply options. The optional accessories inside makes the Home Hub can be used to cooperate with the GM Energy Inverter or other residential energy storage solution.

Meter

Meter is used by the GM Energy Inverter to import / export consumption readings, and manage the battery charge / discharge accordingly for smart energy management applications, for example self-consumption, zero-export or TOU. Meter reports its electricity measuring value to GM Energy Inverter via RS485 following Modbus.To meet UL 1741 PCS CRD requirements, the meter must be installed.

Grid

240V / 208V grid are supported, and it can be configured via PowerShift Install App.

Android/iOS App

A very powerful tool for monitoring, configuration or diagnosis. PowerShift Install App is connected to GM Energy Inverter.

Current Transformer

Current transformer can detect the current of controlled conductor. It is shipped together with the Meter. For CT installation, please refer to the system installation manual.

2.2 Data Evaluation And Communication

The integrated interface, processing and communication of the device enables easy operation of the V2H system. Monitoring of the operational status and signaling of operational failures are capable of being called up over the interface. The data interfaces enable the downloading of data which can be evaluated with the aid of a PC system and allow continuous recording of operating data.

The best way of accessing this functionality is via a monitoring system connected to your V2H system.

2.3 Technical Structure Of GM Energy Home Hub

Metering and remotely-controllable relays on each circuit give homeowners the ability to monitor home energy usage and manage energy consumption precisely. During an outage the Home Hub automatically detects loss of grid power and disconnects from the utility grid, allowing backup energy storage systems to provide power to the home. With GM Energy Inverter it can support both 120 V and 240 V loads in a grid outage. With GM Energy Home Hub, it can use compatible electric vehicle batteries to backup certain home appliances.

The high-quality aluminum casing corresponds to protection degree NEMA 3R and is protected by an anti-corrosion finish. GM Energy Home Hub is designed in such a way that operation of the Home Hub is possible at ambient temperatures from -4°F to +122°F (-20°C to +50°C) at full power and optimal efficiency for 240 Vac AC grids.

Metal fins designed into the rear side of the GM Energy Home Hub chassis are used to dissipate heat and protect the unit. An internal temperature control protects the interior of the device. In case of high ambient temperatures, the maximum transferable power is limited.

GM Energy Home Hub is controlled by microcontrollers which provide interface communication and the values and messages via App or cloud.

AC grid monitoring is done by an independent dedicated micro controller set up to meet the requirements of UL 1741, UL 67, UL 869a. This enables a connection of the GM Energy Inverter to the in-house grid.

Operator protection requirements are met by electrically isolating the grid from the PV modules.

GM Energy Home Hub is functional in grid-parallel operation exclusively. An automatically anti-islanding function, which is accepted by a certification agency, guarantees secure disconnection in case of circuit isolation or interruptions in power supply and avoids isolated operation.

2.4 Equipment Overview

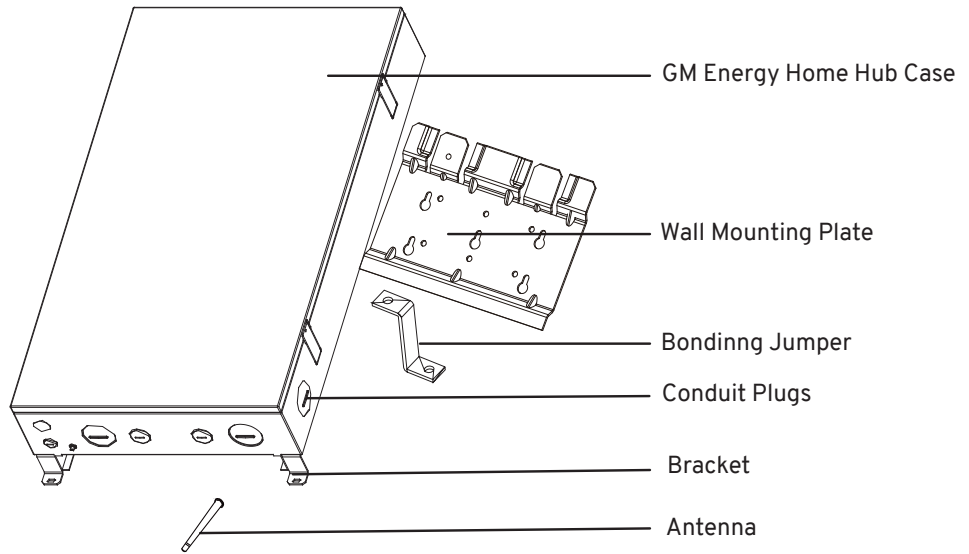

Figure 2: Front view of GM Energy Home Hub with select included accessories

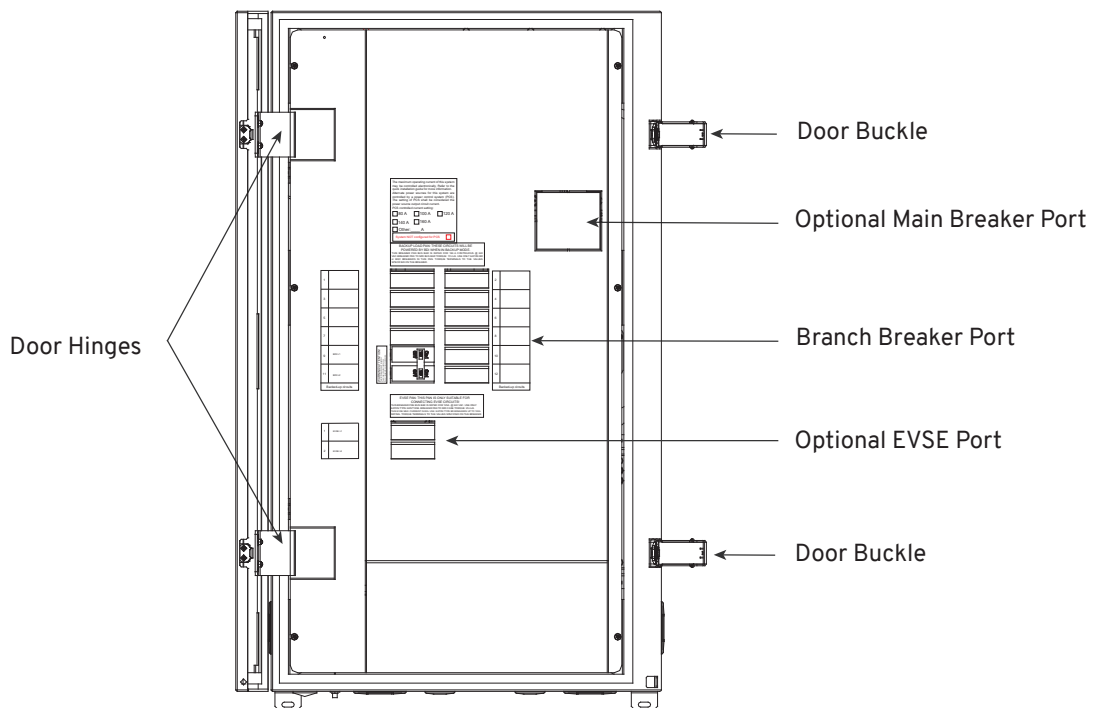

Figure 3: Front view of GM Energy Home Hub with door opened

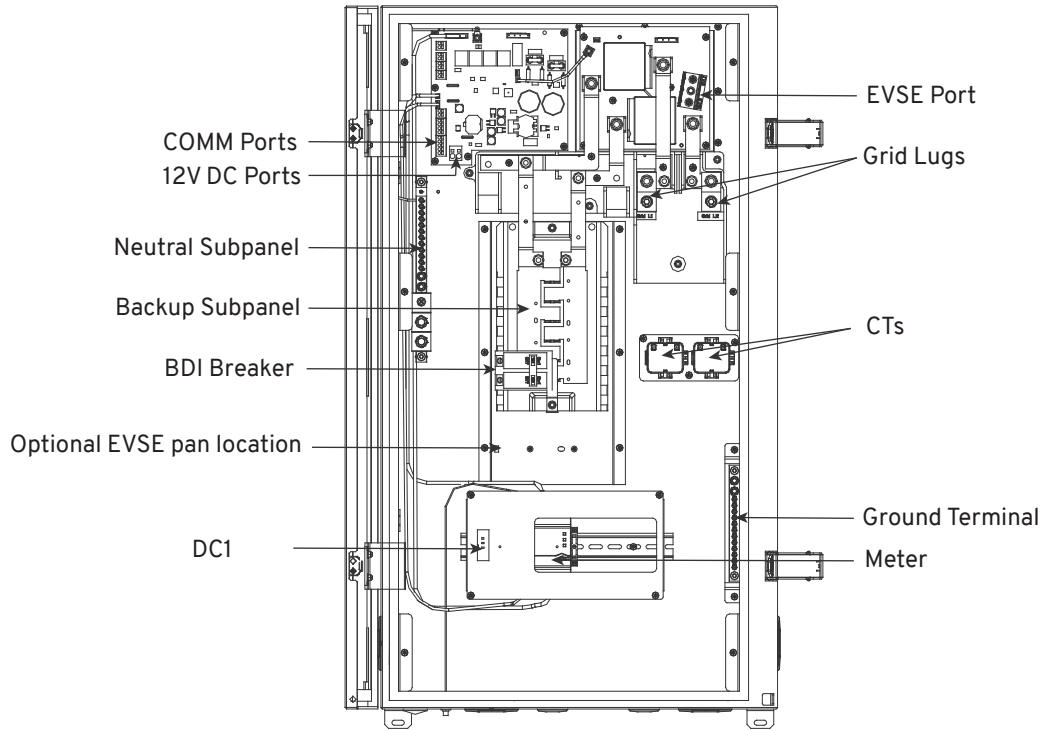

Figure 4: Front view of GM Energy Home Hub with door opened dead cover removed

2.5 GM Energy Home Hub Label And Dimensions

The type label is shown in figure 5. Different type labels can be found on the GM Energy Home Hub. The serial number can be found on the type label.

The main caution labels in English and French are on the left side of the GM Energy Home Hub.

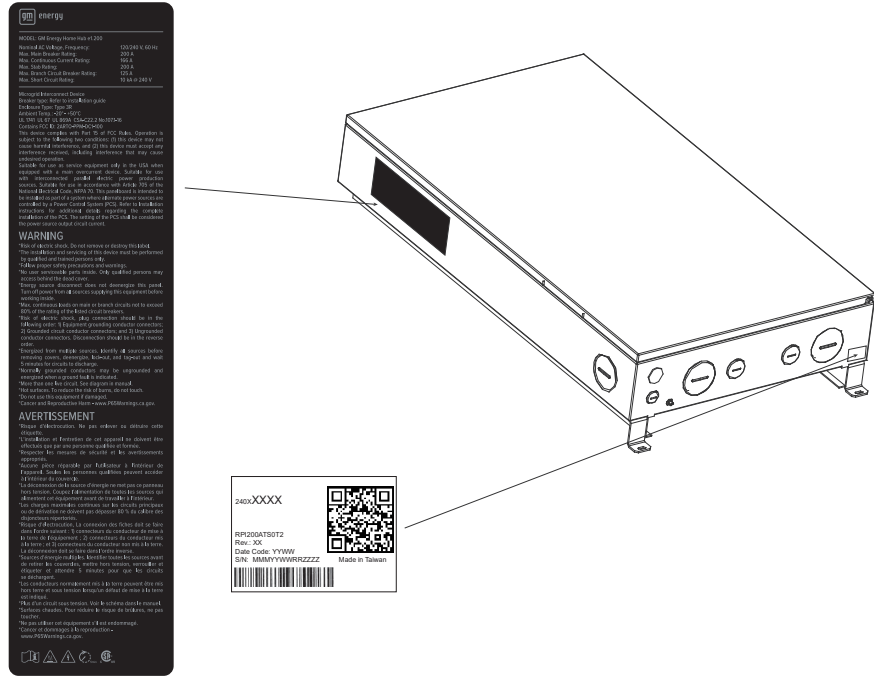

Figure 5: Location of sample label

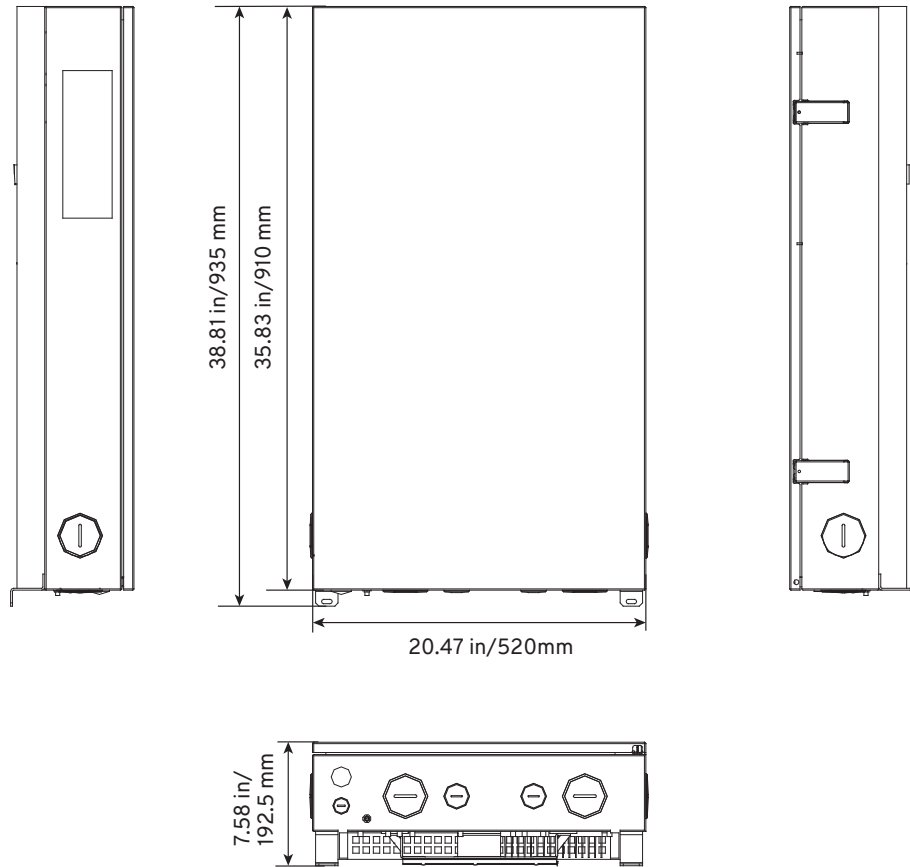

Figure 6: Dimensions of GM Energy Home Hub

3 INSTALLATION



WARNING!

Read all of these instructions, cautions, and warnings for the GM Energy Home Hub.

AVERTISSEMENT!

Lisez toutes les instructions, rubriques Prudence et Avertissement de l'onduleur GM Energy Home Hub.



WARNING!

The installer must be qualified to perform the installation pursuant to the requirements of local ordinances, the National Electric Code, and local building codes. This may include being a Qualified Personnel that is active and in good standing with the state in which they are performing the installation services or working under the direction of such Qualified Personnel.

AVERTISSEMENT!

L'installateur doit être qualifié pour effectuer l'installation conformément aux exigences des ordonnances locales, du code national de l'électricité et des codes de construction locaux. Il peut s'agir d'une Personne Qualifiée, active et en règle avec l'État dans lequel il effectue les services d'installation, ou travaillant sous la direction d'une telle Personne Qualifiée.



WARNING!

The installation and wiring methods used in the installation of GM Energy Home Hub in the U.S. must comply with all US National Electric Code (NEC) requirements and local AHJ inspector requirements. In Canada, the installation and wiring methods used must comply with the Canadian Electric Code, Part I and II, and the local AHJ inspector requirements. System grounding when required by the Canadian Electrical Code, Part I, is the responsibility of the installer.

AVERTISSEMENT!

Les méthodes d'installation et de câblage utilisées lors de l'installation de cet onduleur aux États-Unis doivent être conformes à toutes les exigences du National Electric Code (NEC) nord-américain et à celles des services d'inspection locaux de l'AHJ. Au Canada, les méthodes d'installation et de câblage utilisées doivent être conformes au Canadian Electric Code, Parties I et II et aux exigences des services d'inspection locaux l'AHJ. L'installateur est responsable de la mise à terre du système lorsque requise par le Canadian Electrical Code, Partie 1.



WARNING!

These servicing instructions are for Qualified Personnel use only. To reduce the risk of electric shock, refer all servicing to factory qualified service personnel. No user service parts are contained inside the GM Energy Home Hub.

AVERTISSEMENT!

Ces instructions d'entretien sont réservées à un Personnel Qualifié. Pour réduire le risque d'électrocution, confiez toutes les opérations d'entretien à un personnel qualifié de l'usine. Le GM Energy Home Hub ne contient aucune pièce destinée à l'entretien par l'utilisateur.



WARNING!

The GM Energy Home Hub is heavy (see 11.2 Technical data), must be lifted and carried by at least two people.

Handle with care, do not drop, impact Home Hub during installation to prevent damage.

AVERTISSEMENT!

Le GM Energy Home Hub est lourd (voir 11.2 Caractéristiques techniques), il doit être soulevé et porté par au moins deux personnes.

Manipuler avec précaution, ne pas laisser tomber, ne pas heurter le Home Hub pendant l'installation afin d'éviter tout dommage.



CAUTION!

For the specified temperature range, the BR thermal-magnetic breakers may trip slowly at the temperature $<0^{\circ}\text{C}$ due to nature characteristics of thermal-magnetic type breakers. It shall use the breaker with proper rating at negative temperature per the temperature correction factor provided by the breaker manufacture to ensure the breaker can trip properly under overload condition at negative temperature.

PRUDENCE!

Pour la plage de température spécifiée, les disjoncteurs magnétothermiques BR peuvent se déclencher lentement à une température inférieure à 0°C en raison des caractéristiques naturelles des disjoncteurs magnétothermiques. Il convient d'utiliser le disjoncteur ayant le calibre approprié à une température négative, conformément au facteur de correction de la température fourni par le fabricant du disjoncteur, afin de s'assurer que le disjoncteur peut se déclencher correctement en cas de surcharge à une température négative.



CAUTION!

The secondary short-circuit current rating is increased at the transfer connection point to the public electricity supply system by the nominal current of the connected GM Energy Home Hub.

PRUDENCE!

Le courant nominal secondaire du court-circuit est augmenté au point de connexion du transfert vers le réseau électrique public par le courant nominal de l'onduleur Home Hub.



CAUTION!

To reduce the risk of fire, connect only to a circuit provided with branch circuit over current protection in accordance with the National Electrical Code, ANSI/NFPA70.

PRUDENCE!

Afin de réduire les risques d'incendie, effectuez une connexion uniquement avec un circuit équipé d'une protection contre les surintensités des circuits de dérivation, conformément au National Electrical Code, ANSI/NFPA70.



INFORMATION!

In order to be able to carry out an energy measurement, a KWH revenue meter must be attached between the networks feed-in point and the device.

INFORMATIONS!

Pour pouvoir effectuer une mesure de l'énergie, un compteur de KWH doit être installé entre le point d'alimentation du réseau et l'appareil.

3.1 Visual Inspection

All GM Energy Home Hubs are 100% tested, packaged in a heavy duty cardboard shipping carton, and visually inspected before leaving our manufacturing facility. If you receive the Home Hub in a damaged shipping carton, please reject the shipment and notify the shipping company.

Verify GM Energy Home Hub shipping carton contains:

- a. Correct model: GM Energy Home Hub e1.200
- b. Mounting plate
- c. Quick installation Guide
- d. Antenna
- e. Jumper kit: Main Service Bonding Jumper*1, M4 screw*2
- f. Main breaker wiring kit: Main Service Disconnect label*1, M4 nut*1
- g. AC solar wiring kit: AC solar warning label*1

Visually inspect the GM Energy Home Hub for any physical damage such as dented chassis.

If the Home Hub appears to be damaged or if the GM Energy Home Hub needs to be returned, please contact your local GM Energy representative at 1-833-64POWER.

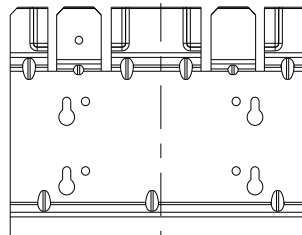
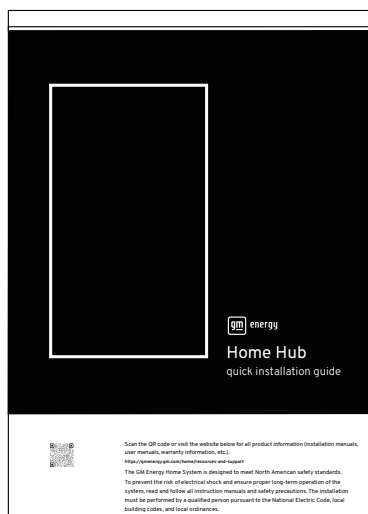

b

c

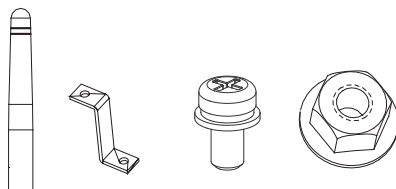

d

e

e

f



f



g



Do not attempt to open, disassemble, repair, tamper with, or modify the equipment other than what is permitted in this manual. The equipment contains no user-serviceable parts other than field-installed circuit breakers. Contact the installer who installed the equipment for any repairs. Failure to comply may result in voiding of any applicable warranty. See Limited Warranty for details.

N'essayez pas d'ouvrir, de démonter, de réparer, d'altérer ou de modifier l'équipement autrement que dans les conditions prévues par le présent manuel. L'équipement ne contient aucune pièce réparable par l'utilisateur autre que les disjoncteurs installés sur place. Pour toute réparation, contacter l'installateur qui a installé l'appareil. Le non-respect de cette règle peut entraîner l'annulation de toute garantie applicable. Voir la garantie limitée pour plus de détails.

3.2 Installation Location

1. Install the GM Energy Home Hub on a non-flammable support base.
2. The GM Energy Home Hub must be mounted vertically on a flat surface.
3. A minimum distance of 6 inches (15.2 cm) of unobstructed clearance on all sides to promote free convection is required.
4. Ensure the mounting hardware and structure can support the weight of the Home Hub.
5. Ensure the mounting hardware meets the appropriate building code.
6. Avoid installation on resonating surfaces (light construction walls etc.).
7. Installation can be indoors or in protected outdoor areas.
8. Sun shading recommended when located in direct sunlight where ambient temperatures can exceed 104 °F (40 °C).
9. Ensure GM Energy Home Hub ambient temperature is within -4 °F to 122 °F (-20 °C to 50 °C).
10. Despite having a NEMA 3R enclosure with a soiling category III certification, the GM Energy Home Hub must not be exposed to heavy soiling.
11. Unused connectors and interfaces must be covered with sealing connectors.

3.3 Mounting The GM Energy Home Hub

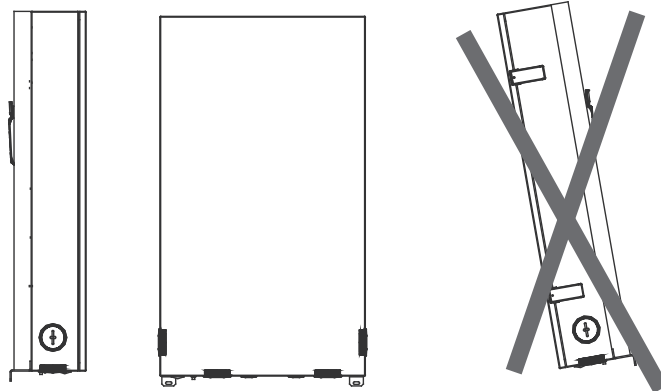
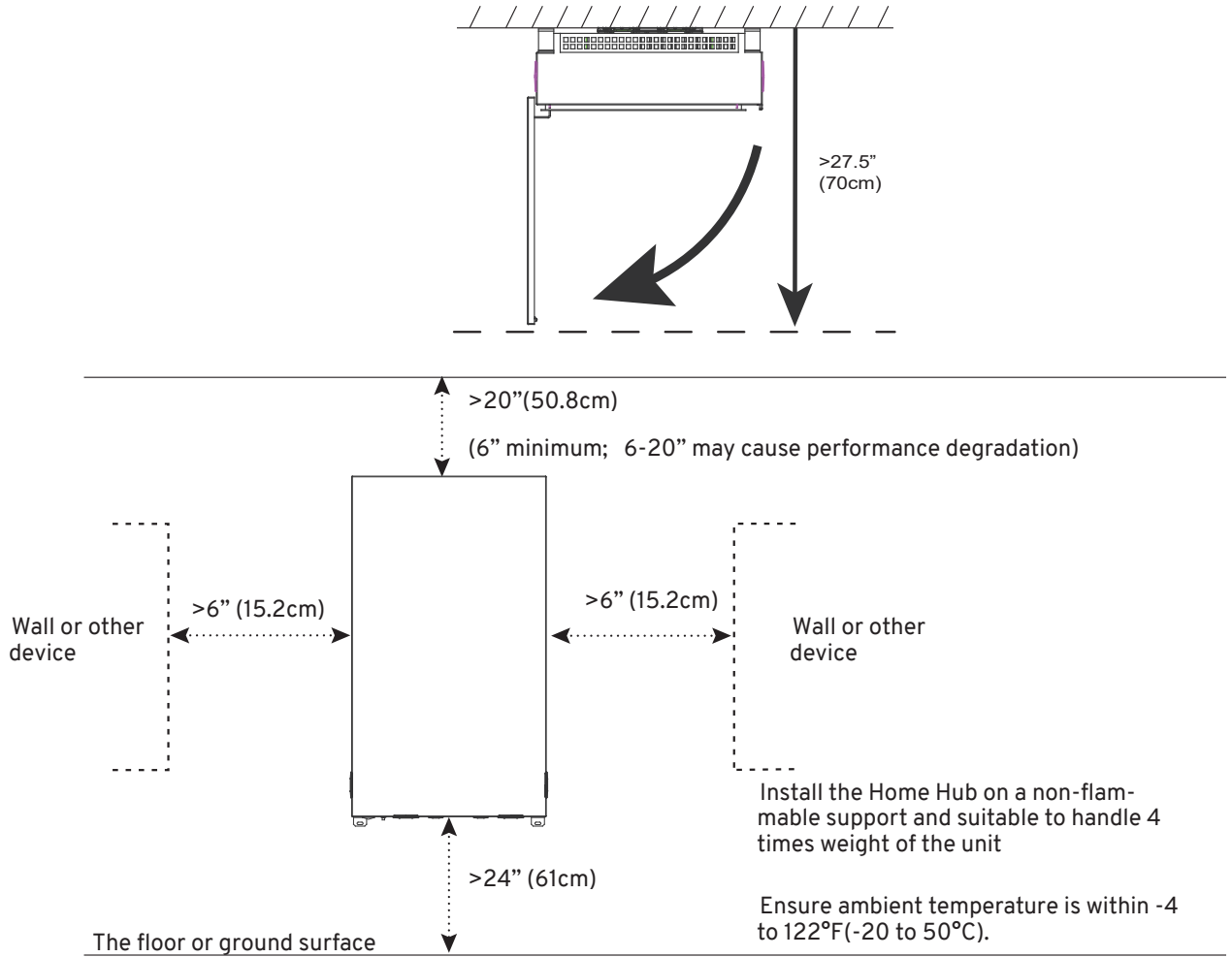

Figure 7: Mounting directions

Please make sure the GM Energy Home Hub is installed vertically with a maximum incline of $\pm 5^\circ$ on a flat surface especially if it is to be installed outdoors.



Note: All dimensions are recommend

Figure 8: Installation clearances

The National Electric Code may require additional working clearances (see NEC Section 110.26).

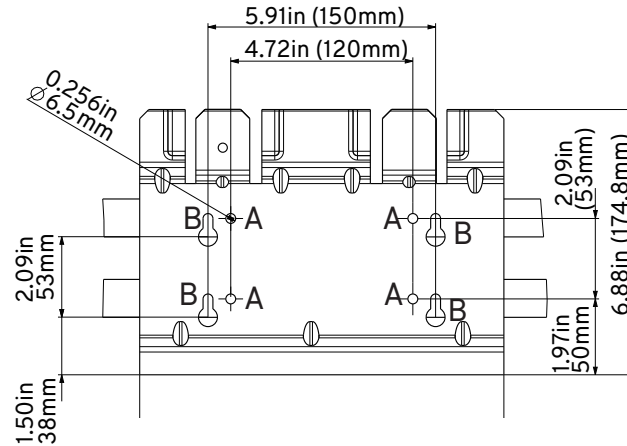

Figure 9: Dimension drawing of mounting plate

1. Mount the mounting plate to the wall with at least 4 screws and anchors (\emptyset 6mm). With 4 screws use 4 holes A or 4 holes B (see Figure 9). You can use the mounting plate as a template for marking the positions of the boreholes. Avoid installation on a non-load bearing wall.
2. Tighten the screws firmly to the wall. Make sure the wall can handle the weight at least 143.3 lbs(65 kg).

- Concrete, cinder Block, or Red Brick Masonry Wall

Minimum strength must be 2500 PSI (concrete) or 1500 PSI (masonry). Use at least four (one in each corner, in any available anchor slot) 1/4-inch fasteners(\emptyset 6) with washers, of sufficient length for at least 1.5 in (38 mm) embedment into the material. Ensure that all fasteners are at least 1.5 in (38 mm) away from the edges of masonry blocks or bricks.

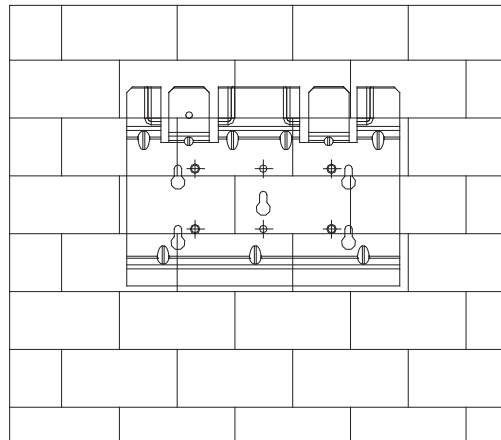

Figure 10: Mount to concrete / brick wall

- Sheathed Wall with Wood Studs (covering finish: gypsum board, Stucco, wood siding+latching, straping+wood siding)

Anchoring between wood studs: Use minimum 2 x 4 in blocks, end-nailed into studs with two 16d nails or toenailed into studs with four 8d nails. Drill the wall for at least 4 sets 1/4" wood screws with washers, of sufficient length for at least 2.5 in embedment into the studs.

Anchoring on one wood stud: Drill the wall for at least 2 sets 1/4" wood screws with washers, of sufficient length for at least 2.5 in embedment into the middle of the studs. And 2 sets 1/4" wood screws on each side with washers for auxiliary fixation.

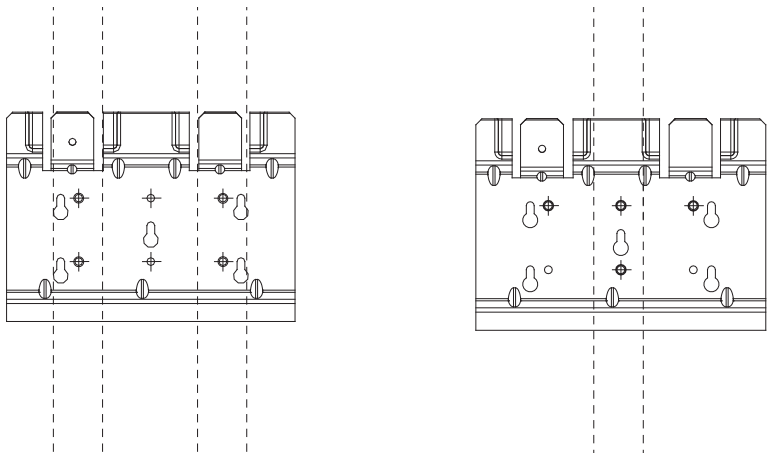
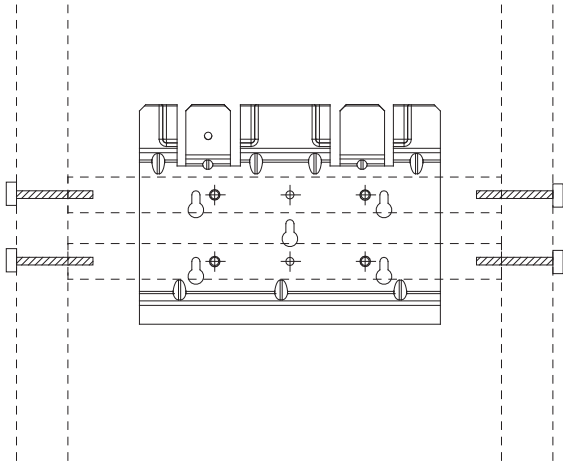

Figure 11: Mount to wood studs

- Wood Studs

If anchoring to blocking between wood studs, use minimum 2 x 4 in blocks, end-nailed into studs with two 16d nails or toenailed into studs with four 8d nails. Use at least four 1/4-inch wood screws with washers, of sufficient length for at least 2.5 in embedment into the blocking.



- Plywood

If anchoring to plywood wall material, the plywood must be minimum 1/2-inch thick. Use at least four 1/4-inch wood screws with washers, of sufficient length to penetrate at least 1/4 inch beyond the backside of the plywood.

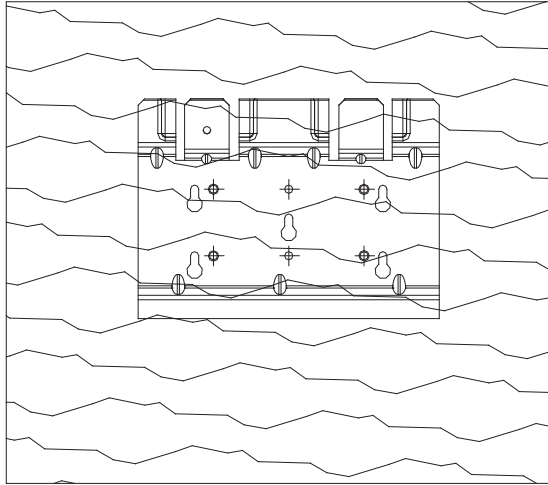

Figure 12: Mount to plywood

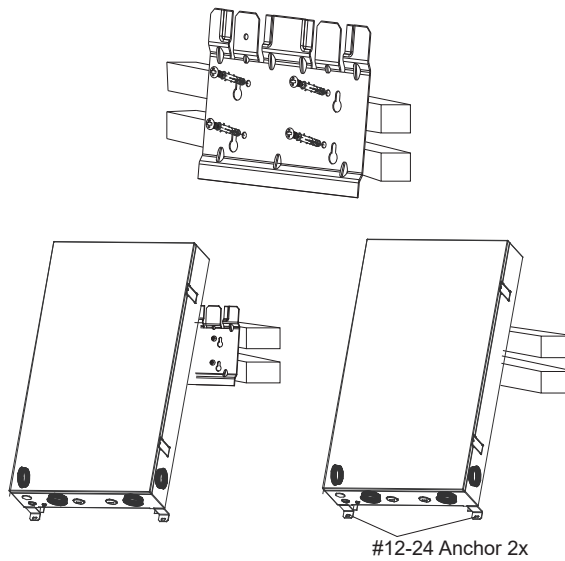

Figure 13: Installing the plate and Home Hub on a wood stud wall

This unit is designed to be wall-mounted. Please ensure the installation is perpendicular to the floor and the door can be opened easily. Do not install the device on a slanting wall. The dimensions of the mounting plate are shown in the figure 9.

1. Using the mounting plate as a template, mark four screw holes onto the wall. Use the four holes that are indicated for this purpose in the figure 9. Make sure the holes are in the center of each stud before marking the drill location.
2. After marking the screw hole locations, drill the pilot holes for the appropriate screw type that will hold the weight of the GM Energy Home Hub in the selected material. 1/4" lag bolts are recommended for mounting on wood framed walls.
3. Align the mounting plate over the pilot holes and install the mounting hardware to mounting surface. Please tighten to the recommended torque necessary to hold the mounting plate firmly to the wall surface type.
4. As the GM Energy Home Hub is heavy, weighs around 45.2 lbs (20.5 kg), size around 20.5 × 35.8 × 7.56 in (520 × 910 × 192 mm), it is recommended to lift out of the cardboard container by at least two persons.
5. With at least one person on each side of the GM Energy Home Hub, lift it up and place it carefully onto the mounting plate. Install two #12-24 Anchors as shown in the figure 9 to secure the device.
6. Check that the device is seated securely on the wall.

It is recommended to use stainless steel screws, especially if installed outdoors. Be sure to verify shear and pullout strength of anchors or other wall attachments.

4 ELECTRICAL CONNECTIONS

4.1 Important Safety Information



DANGER!

The device produce hazardous voltages and currents when exposed to light which can create an electrical shock hazard. Turn off all power supplying this equipment before working on or inside equipment.

DANGER!

L'appareil produit des tensions et des courants dangereux lorsqu'il est exposé à la lumière, ce qui peut créer un risque d'électrocution. Couper l'alimentation électrique de l'appareil avant de travailler sur ou à l'intérieur de l'appareil.



WARNING!

Read all of these instructions, cautions, and warnings for the GM Energy Home Hub.

AVERTISSEMENT!

Lisez l'ensemble de ces instructions, mises en garde et avertissements concernant le GM Energy Home Hub.



WARNING!

Installation and commissioning must be performed by Qualified Personnel that are licensed and/or satisfied state and local jurisdiction regulations in accordance with local, state, and National Electrical Code ANSI/NFPA 70 requirements. Use the wire gauge that have the ampacity based on NEC code and 90°C (194 °F) copper solid or stranded wire for all wiring to the GM Energy Home Hub to optimize system efficiency.

AVERTISSEMENT!

L'installation et la mise en service doivent être effectuées par du Personnel Qualifié qui possède une licence et/ou qui satisfait aux réglementations de l'État et de la juridiction locale conformément aux exigences locales, de l'État et du Code national de l'électricité ANSI/NFPA 70. Utilisez le calibre de fil qui a l'ampacité basée sur le code NEC et 90°C (194 °F) cuivre solide ou toronné pour tout le câblage au GM Energy Home Hub afin d'optimiser l'efficacité du système.



WARNING!

Before connecting the GM Energy Home Hub to the AC distribution grid, approval must be received by appropriate local utility as required by national and state interconnection regulations, and must be connected only by Qualified

Personnel.

AVERTISSEMENT!

Avant de raccorder la GM Energy Home Hub au réseau de distribution de courant alternatif, il est nécessaire d'obtenir l'autorisation du service public local compétent, conformément aux réglementations nationales et régionales en matière d'interconnexion, et le raccordement ne doit être effectué que par du personnel qualifié.



WARNING!

Do not use this equipment if damaged.

AVERTISSEMENT!

N'utilisez pas cet équipement s'il est endommagé.



WARNING!

Do not use equipment where exposed to flammable vapours.

AVERTISSEMENT!

Ne pas utiliser l'équipement en cas d'exposition à des vapeurs inflammables.



CAUTION!

Do not attempt to open or repair the Home Hub as the Home Hub is factory sealed to maintain its NEMA 3R rating and will void the GM Energy Home Hub limited warranty.

PRUDENCE!

N'essayez pas d'ouvrir ou de réparer le Home Hub car il est scellé en usine pour conserver sa classification NEMA 3R et annulera la garantie limitée du GM Energy Home Hub.



CAUTION!

The output circuits are isolated from the enclosure. The Equipment Grounding Conductor (EGC) when required by National Electric Code (NEC), is the responsibility of the installer.

PRUDENCE!

Les circuits de sortie sont isolés du boîtier. Le conducteur d'électrode de terre



(GEC), lorsqu'il est exigé par le National Electric Code (NEC), relève de la responsabilité de l'installateur.

NOTICE!

For use with compatible electric vehicles.

AVIS!

Pour les véhicules électriques compatibles.

4.2 Utility AC Voltage

The GM Energy Inverter with GM Energy Home Hub are grid-tied to the public utility. The V2H system is software configurable panel for 240 Vac 60 Hz public utility grid as shown in figure 14 to figure 18.



CAUTION!

The GM Energy Home Hub should never be connected to a 120 Vac utility service. NEC 705 requires that the GM Energy Home Hub be connected to a dedicated circuit with no other outlets or devices connected to the same circuit.

PRUDENCE!

Le GM Energy Home Hub ne doit jamais être connecté à un service public de 120 Vac. La norme NEC 705 exige que le GM Energy Home Hub soit connecté à un circuit dédié, sans autres prises ou appareils connectés au même circuit.

AC Connection Voltage And Frequency Limits

Voltage Range For 240 V	211 V - 264 V
Frequency Range	59.3 Hz - 60.5 Hz

Table 1: AC connection voltage and frequency limits

Examples Of Public Grid Configurations Allowed

<p>240V \angle 180°</p>	<p>240V \angle 120°</p> <p>240V \angle 120°</p> <p>240V \angle 120°</p>
<p>Figure 14: 240V / 120V Split Phase AC Grid</p>	<p>Figure 15: 240V / 120V Stinger AC Grid</p>

Examples Of Public Grid Configurations NOT Allowed

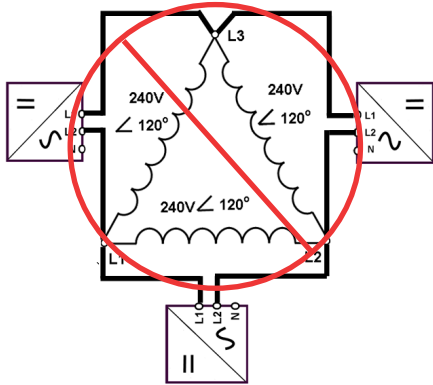

Figure 16: 240V Delta AC Grid

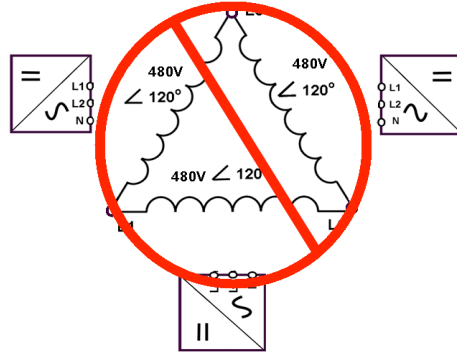

Figure 17: 480V Delta AC Grid

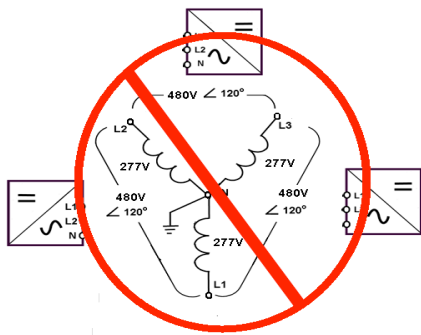

Figure 18: 480V / 277V WYE AC Grid

4.3 AC Circuit Breaker Requirements

GM Energy Inverter is designed to withstand a Max.10kA fault current interrupt rating, and GM Energy Home Hub has a Max, 10 kA fault current interrupt rating. A dedicated circuit breaker in the building circuit panel is required for the GM Energy Home Hub. A separate dedicated circuit breaker for the GM Energy Inverter will be located in the GM Energy Home Hub. There must be a circuit breaker or fuse to protect each AC line, L1 and L2. The circuit breaker must be able to handle the rated maximum output voltage and current of the GM Energy Inverter. Please refer to the table 2 below to determine the appropriate circuit breaker size to avoid potential fire hazards. The National Electrical Code (NEC), ANSI/NFPA 70 or applicable local electrical codes must be followed when determining maximum branch-circuit over-current protection requirements.

Suggested Branch Protection		
Model Name	Suggested AC Branch Protection	Recommended AC wire gauge
GM Energy Inverter e1.11	2-pole, 60 A 240 Vac	6 AWG Copper
GM Energy Home Hub e1.200	2-pole, 200 A 240 Vac	3/0 Copper

Table 2: Suggested branch protection

For GM Energy Home Hub, the rating of AC branch protection can be selected according to the load condition. The wire gauge can be selected according to the AC branch protection.

4.4 Equipment Grounding Conductor (EGC)

Grounding must be installed in accordance with NEC 250. The EGC conductor should be terminated at the EGC screw terminal(PE/G) inside the GM Energy Home Hub compartment.

4.5 Main Bonding Jumper(Optional)

The GM Energy Home Hub is listed for use as the Main Service Panel. When installed as the Main Service Panel, the Neutral to Grounding bonding jumper must be installed. (Previous bonding jumper must be removed).

Note:

- Bonding jumper is provided as an accessory by GM. Make sure the bonding jumper is correctly installed if the device is used as a main service panel.

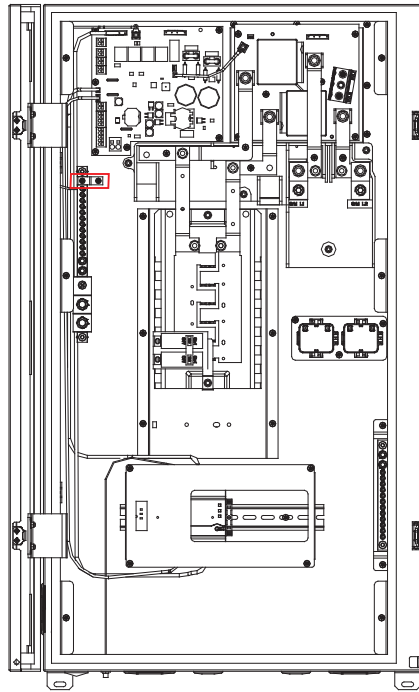

Figure 19: Main bonding jumper

4.6 GM Energy Home Hub Connections

4.6.1 Important Safety Information



DANGER!

Device produce hazardous voltages and currents when exposed to light which can create an electrical shock hazard. Turn off all power supplying this equipment before working on or inside equipment. Always use a properly-rated voltage sensing device to confirm power is off. Replace all devices, covers, and doors before turning on power to the equipment.

DANGER!

L'appareil produit des tensions et des courants dangereux lorsqu'il est exposé à la lumière, ce qui peut créer un risque d'électrocution. Couper l'alimentation électrique de l'appareil avant de travailler sur ou à l'intérieur de l'appareil. Utilisez toujours un dispositif de détection de tension approprié pour confirmer que l'appareil est hors tension. Remettre en place tous les dispositifs, couvercles et portes avant de remettre l'équipement sous tension.



WARNING!

Input and output circuits of this unit are isolated from the enclosure. System grounding must be done in accordance with the National Electrical Code (NEC), ANSI/NFPA 70 and compliance is the responsibility of the installer.

AVERTISSEMENT!

Les circuits d'entrée et de sortie de cette unité sont isolés du boîtier. La mise à la terre du système doit être effectuée conformément au National Electrical Code (NEC), ANSI/NFPA 70, et l'installateur est responsable de cette mise en conformité.



WARNING!

Energy source disconnect does not deenergize this panel. Turn off power from all sources supplying this equipment before working inside.

AVERTISSEMENT!

La déconnexion de la source d'énergie ne met pas ce panneau hors tension. Coupez l'alimentation de toutes les sources qui alimentent cet équipement avant de travailler à l'intérieur.



WARNING!

Risk of electric shock, Plug connection should be in the following order: 1) Equipment grounding conductor connectors; 2) Grounded circuit conductor connectors; and 3) Ungrounded conductor connectors. Disconnection should be in the reverse order.

AVERTISSEMENT!

Risque d'électrocution, La connexion des fiches doit se faire dans l'ordre suivant : 1) connecteurs du conducteur de mise à la terre de l'équipement ; 2) connecteurs du conducteur du circuit mis à la terre ; et 3) connecteurs du conducteur non mis à la terre. La déconnexion doit se faire dans l'ordre inverse.



WARNING!

Installation and commissioning must be performed by Qualified Personnel that are licensed and/or satisfied state and local jurisdiction regulations in accordance with local, state, and National Electrical Code ANSI/NFPA 70 requirements.

AVERTISSEMENT!

L'installation et la mise en service doivent être effectuées par du Personnel Qualifié, titulaire d'une licence et/ou satisfaisant aux réglementations de l'État et de la juridiction locale, conformément aux exigences locales, de l'État et du Code national de l'électricité (ANSI/NFPA 70).



WARNING!

Do not insert foreign objects into any part of the equipment.

AVERTISSEMENT!

Do not expose the equipment or any of its components to direct flame.



WARNING!

Energized from multiple sources. Identify all sources before removing covers , de-energize, lock-out, and tag-out and wait 5 minutes for circuits to discharge.

AVERTISSEMENT!

Sources d'énergie multiples. Identifier toutes les sources avant de retirer les couvercles, mettre hors tension, verrouiller et étiqueter et attendre 5 minutes pour que les circuits se déchargent.



WARNING!

Max. continuous loads on main or branch circuits not to exceed 80% of the rating of the listed circuit breakers.

AVERTISSEMENT!

Les charges continues maximales sur les circuits principaux ou de dérivation ne doivent pas dépasser 80 % du calibre des disjoncteurs répertoriés.



WARNING!

POWER FED FROM MORE THAN ONE SOURCE, MORE THAN ONE LIVE CIRCUIT. Please note that all terminals may carry current even without connected wires.

AVERTISSEMENT!

Alimentation puissance provenant de plus d'une source, plus d'un circuit vivre. Veuillez noter que toutes les terminaux peuvent transporter le courant, même sans fils reliés.



CAUTION!

Before any electrical wiring can be connected to the GM Energy Home Hub, the Home Hub must be permanently mounted.

PRUDENCE!

Le Home Hub GM Energy doit être monté de manière permanente avant de pouvoir être raccordé au réseau électrique.

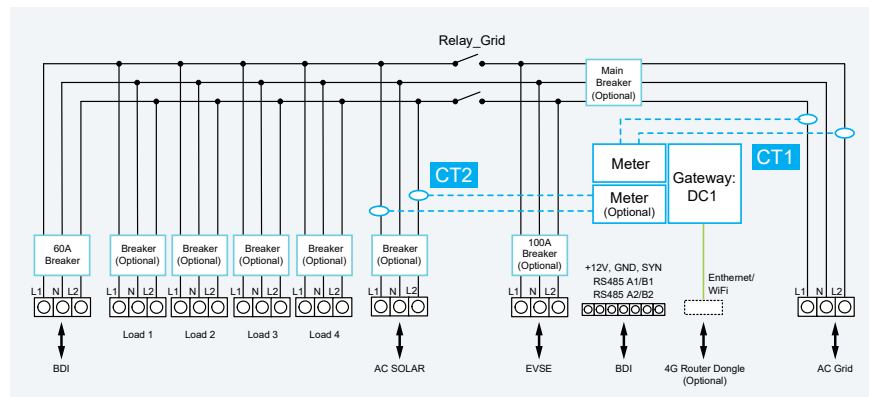

Figure 20: GM Energy Home Hub electrical diagram

4.6.2 Installation Requirements



WARNING!

Before making any connections verify that the circuit breaker(s) are in the off position. Double check all wiring before applying power.

AVERTISSEMENT!

Avant d'effectuer toute connexion, vérifiez que le(s) disjoncteur(s) est (sont) en position d'arrêt. Vérifiez à nouveau l'ensemble du câblage avant de mettre l'appareil sous tension.

Material Requirements:

1. Branch circuit breakers for load circuits as required.
2. Main Breaker using type CSR sized xxx2100N (100A) - xxx2200N (200A).
3. Raceway such as conduit, fittings, straps, wire splice materials, ferrules and spade connectors and fasteners.
4. Conductors rated to minimum of 75°C. See table 3 below and markings on breakers for acceptable wire gauge.
5. Cable for communication between the GM Energy Home Hub and GM Energy Inverter (Minimum 300 V rated, shielded, twisted-pair, copper, 23-14 AWG).
6. Smartphone or tablet with GM Energy Home Hub Installer App for commissioning Personal Protective Equipment (PPE) should be worn by all persons at the installation site and properly rated for residential applications.

Required Tools:

1. Safety PPE: safety glasses, gloves, head, ear, and foot protection, NFPE-70 arc flash protection.
2. Electrical tools for installing equipment, raceways, circuits, and to migrate circuits: Power tools, Assorted Drill bits, pipe bender(s), channel lock pliers, caulking gun.
3. Torquing tools capable of 20-275 in-lbs (2.3-31.1 Nm).
4. Allen bits (3/8-inch and 5/16-inch).
5. T-20 Torx Bit
6. Phillips, slotted, and square-drive driver.
7. Standard installation tools: wire cutters/strippers, multimeter, stud finder, level, tape measure, marker, and flashlight.

Note:

- Main Breaker Required when GM Energy Home Hub serves as service panel.
- Verify that the site mechanical, electrical, and clearance requirements outlined in this document and the product datasheet are compatible at the planned installation location.
- Install only compatible circuit breakers, conductors, and other accessories. Failure to do so may affect safety, product performance, and may void any applicable limited warranty.
- NEMA 3R rated conduit fittings are required for outdoor installations.

4.6.3 GM Energy Home Hub Conduit Plugs

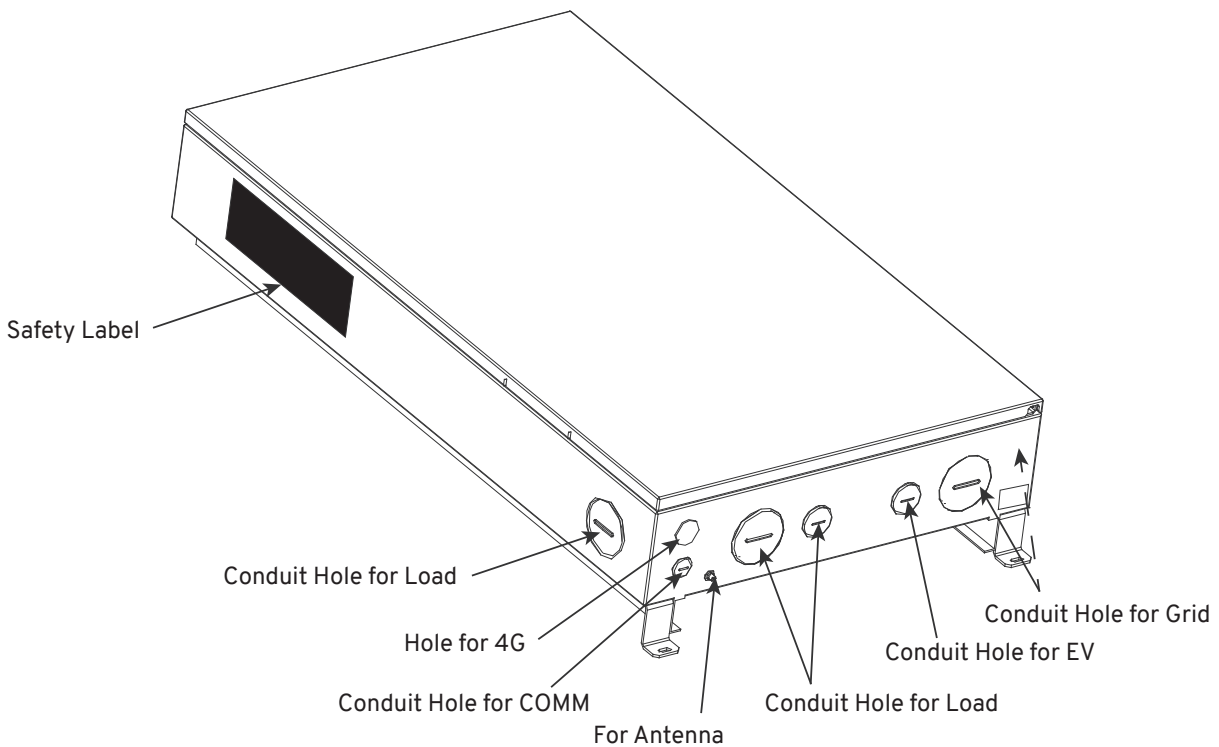

Figure 21: Locations of GM Energy Home Hub conduit plugs



CAUTION!

Do not enlarge the wiring compartment conduit openings as the GM Energy Home Hub enclosure will be damaged which will void the Home Hub limited warranty.

PRUDENCE!

N'agrandissez pas les ouvertures des conduits du compartiment de câblage car le boîtier du GM Energy Home Hub serait endommagé, ce qui annulerait la garantie limitée du Home Hub.

4.6.4 Installed As Service Equipment (Optional)

This applies when installing the GM Energy Home Hub as a main service equipment.

Installation steps

0. Check the jumper kit before install, Jumper kit: Jumper, M4 screw *2
1. Install Main Service Bonding Jumper Kit: Jumper, M4 Screw x2 by securing the neutral-grounding bonding strap to the Neutral (N) bar and the GM Energy Home Hub enclosure; Secure with the two M4 Screws, one into the Neutral bar, second into the Home Hub case. Torque each screw with a T20 torque screwdriver to 14 in-lbs.
2. Install Main Breaker.
 - Completely remove the two utility feeder chair lugs and nuts securing them with a 1/2" socket wrench, remove the M4 nut from the threaded rod for later re-installation.
 - Place the main breaker tabs onto the threaded studs of the Home Hub bus-sing, and with the housing around the M4 threaded stud at the bottom. Tighten the breaker tabs in position with two 1/4"-20 threaded flange nuts* using a 7/16" socket and torque each to 48 in-lbs. Replace the M4 nut to secure the main breaker housing to the Home Hub case and torque to 14 in-lbs.
3. Place the label "SUITABLE FOR USE AS SERVICE EQUIPMENT" / "MAIN SERVICE DISCONNECT" on the dead cover near the main breaker/service disconnect.

Note:

- If Home Hub is not used as service equipment, these labels should not be used.
- 1/4-20 flange nuts included with purchase of main breaker accessory part.
- Install the rubber lug covers (Eaton TICSR300C) around the conductors, and fully over the Home Hub main breaker line side lug terminals.
- When the Home Hub is used as service equipment, bonding jumper **MUST**

be installed, ensure it is securely in place. Also ensure any previous bonding jumper has been removed.



CAUTION!

Do not modify or rewire any factory-installed connections except the bonding jumper, feeder lugs, or the CTs when necessary.

PRUDENCE!

Ne pas modifier ou recâbler les connexions installées en usine, à l'exception du cavalier de liaison, des cosses d'alimentation ou des TC si nécessaire.

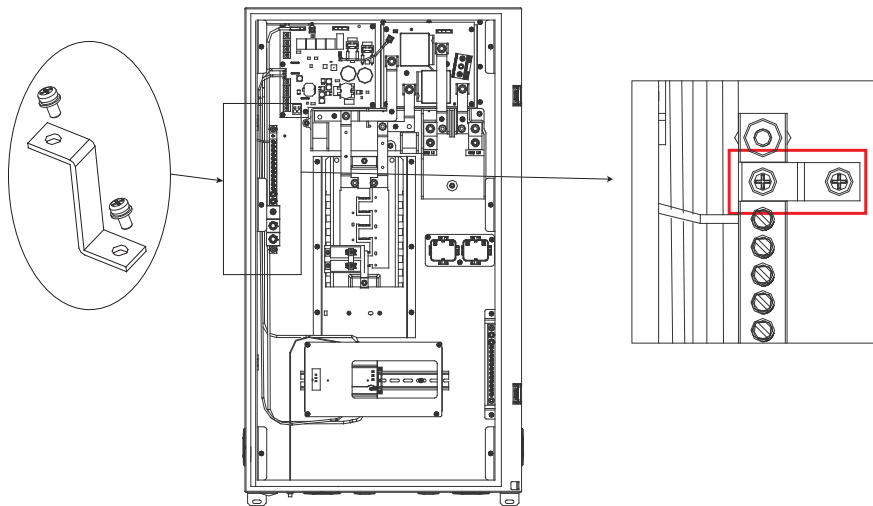

Figure 22: Install the neutral-grounding bonding strap

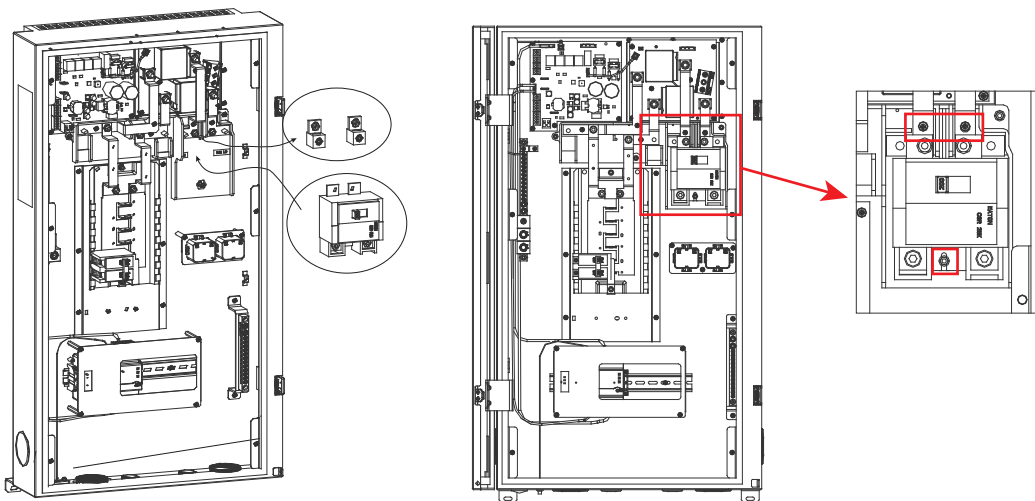

Figure 23: Install the main breaker

4.6.5 Breaker Selection

1. Main Breaker

- Only can accept EATON CSR series: CSR2100 CSR2125N CSR2150N CSR2175N CSR2200N.

2. Subpanel

- GM Energy Home Hub includes one two-pole 60A circuit breaker factory installed that feeds the GM Energy Inverter. Except for the Inverter two-pole breaker, subpanel can hold up to 10 branch circuits. The total current of subpanel cannot exceed 166A. Install additional load breakers as needed. Must follow all NEC and local electrical codes. Recommended Breaker type is EATON BR , BD and BQ series. If AC Solar needs to be connected to the system, recommended location as below.
- For Max. AC solar capacity vs. main breaker size to meet 120% rule per NEC 705.13.

Breaker Selection	
Main Breaker Size	Max. Breaker Size For AC Solar
200 A	0 A
175 A	25 A
150 A	50 A
125 A	75 A
100 A	100 A

Note:

- If there is an external main breaker, the GM Energy Home Hub feeder breaker size is 200 A.
- See PCS configurations for additional options adding AC solar to the system (Section 5).

3. Optional EVSE panel and breaker

- When EVSE AC circuit needs to originate in the GM Energy Home Hub, install a EATON type 24INT125B in the reserved Non-backup/EVSE position, use two pole breaker type EATON BR up to 100A.

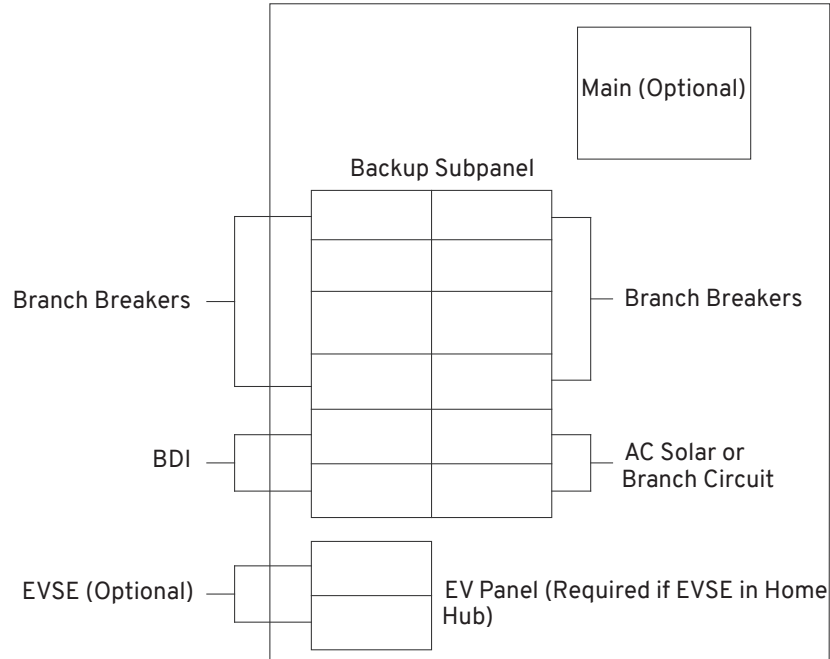

Figure 24: Breakers selection

Breaker Selection	
Main Breaker Size	Eaton CSR2100 CSR2125N CSR2150N CSR2175N CSR2200N
Branch Breaker	Eaton BR thermal magnetic circuit breaker: BR Series up to BR2125 BD Series up to BD5050 BQ Series up to BQ2502120 BQC Series up to BQC2502120 BR Duplex Series up to BR3050
Backfeed Breaker	Eaton BR thermal magnetic circuit breaker: BR220 BR225 BR230 BR250 BR260
EVSE Breaker	Eaton BR thermal magnetic circuit breaker: up to BR2100

Note:

- If AC solar is installed, place the label that reads “WARNING! ATTENTION! Parallel Energy Source Disconnect. Power source output connection. Do not relocate this over current device.” on the dead cover near the AC solar breaker.

4.6.6 Installing Raceways And Conductors

1. Remove necessary raceway entry plugs as needed per design.
2. Install and secure raceways. Ensure NEMA3R fittings are used for outdoor locations.
3. Route conductors and cables into the GM Energy Home Hub enclosure.

4.6.7 Wiring GM Energy Home Hub



DANGER!

To ensure maximum protection against hazardous contact voltages while assembling photovoltaic installations, both the positive and the negative leads must be strictly isolated electrically from the protective ground potential (EGC).

DANGER!

Afin d'assurer une protection maximale contre les tensions dont le contact est dangereux lors du montage des installations photovoltaïques, les câbles positifs et négatifs doivent être strictement isolés électriquement de la mise à la terre (EGC).



WARNING!

Risk of electric shock. Risk of fire.

AVERTISSEMENT!

Risque de choc électrique. Risque d'incendie.



WARNING!

Risk of electric shock. Risk of fire. Ensure that all wiring is correct and that none of the wires are pinched or damaged.

AVERTISSEMENT!

Risque de choc électrique. Risque d'incendie. Assurez-vous que tous les câbles sont corrects et qu'aucun fil n'est pincé ou endommagé.



WARNING!

Risk of electric shock. Risk of fire. Before making any connections verify that the circuit breaker(s) are in the off position. Double check

all wiring before applying power.

AVERTISSEMENT!

Risque de choc électrique. Risque d'incendie. Avant d'effectuer toute connexion vérifiez que le(s) disjoncteur(s) est (sont) en position d'arrêt. Vérifiez deux fois tous les câbles avant de mettre l'appareil sous tension.



WARNING!

Risk of electric shock. Risk of fire. Do not wire unused terminals or terminal blocks on the equipment.

AVERTISSEMENT!

Risque de choc électrique. Risque d'incendie. Ne pas câbler les bornes non utilisées ou des borniers non utilisés sur l'équipement.



WARNING!

Risk of electric shock. Improper servicing of the equipment or its components may result in a risk of shock, fire or explosion. To reduce these risks, disconnect all wiring before attempting any maintenance or cleaning.

AVERTISSEMENT!

Risque d'électrocution. Un mauvais entretien de l'appareil ou de ses de ses composants peut entraîner un risque d'électrocution, d'incendie ou d'explosion. Pour réduire ces risques, débranchez tous les câbles avant de procéder à l'entretien ou à la réparation. ces risques, débranchez tous les câbles avant de procéder à l'entretien ou au nettoyage. d'entretien ou de nettoyage.



INFORMATION!

The equipment is intended to operate with a connection to the internet. Failure to maintain an internet connection may impact performance.

INFORMATIONS!

L'équipement est conçu pour fonctionner avec une connexion à l'internet. L'absence de connexion à l'internet peut avoir une incidence sur les performances de l'appareil.



INFORMATION!

For Partial Load Backup scenario, an additional AC panel for backed-up loads is needed before the GM Energy Home Hub connection. Rewire the backed-up loads through this panel.

INFORMATION!

Pour le scénario de sauvegarde de la charge partielle, un panneau CA supplémentaire pour les charges sauvegardées est nécessaire avant la connexion du GM Energy Home Hub. Recâbler les charges sauvegardées à travers ce panneau.

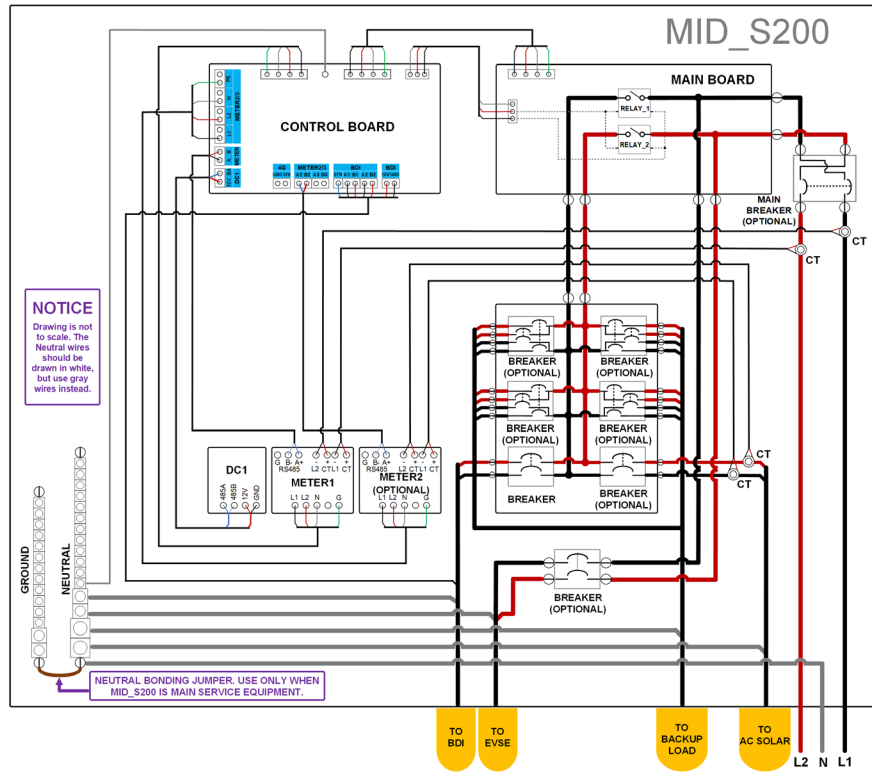

Figure 24: Wiring block of GM Energy Home Hub

Wiring steps

1. Open the door and dead cover.

- Make sure the device is power off then open the buckle cover with a 1/8 Allen wrench as a tool , unbuckle the door and open it. Live operation is not allowed.
- Remove 6x screws on the dead cover with Philips 2 screwdriver, screw torque is 18 in-lbs, and remove the dead cover.
- 2 inches (4x) 1 inches (2x) and 1/2 inches (1x) conduit fittings are provided, remove the conduit plugs which are needed to use.

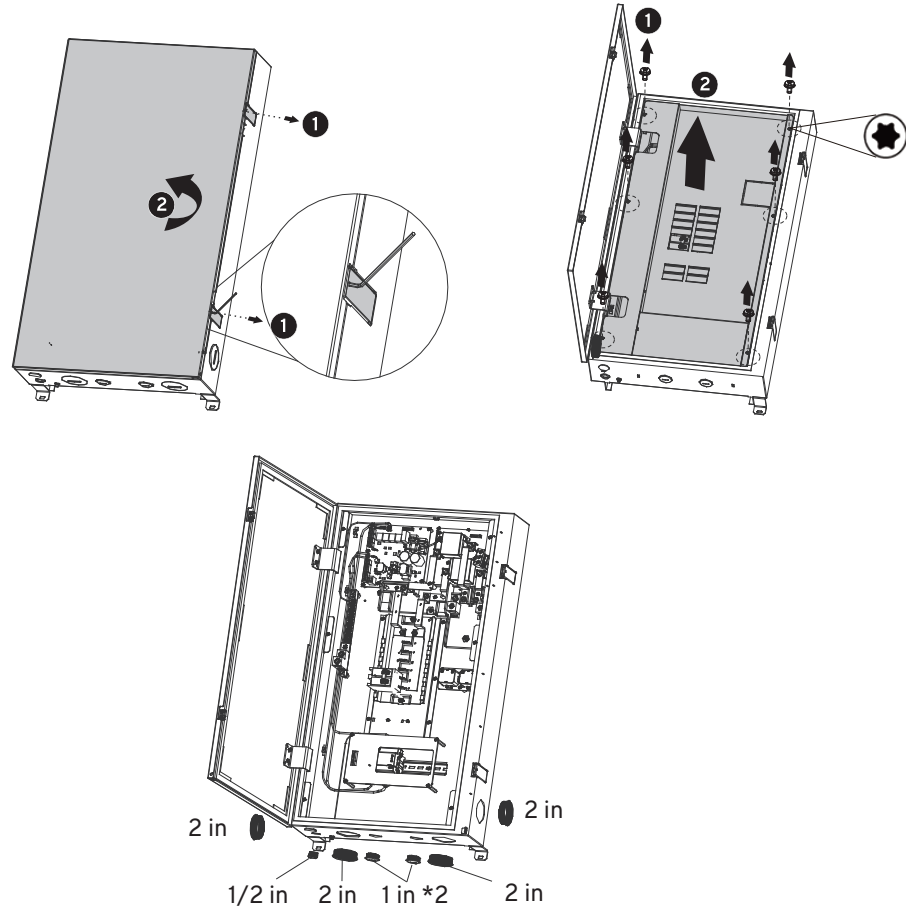

Figure 26: Open the door and dead cover of GM Energy Home Hub

Terminal Wire, Gauge Strip Length And Torque Value					
No.	Terminal Name	Wire Gauge (AWG)	Wire Strip Length (in/mm)	Tool	Torque Value (in-lbs/N-m)
A	Grid and Load Main Lug	#6~250 kcmil	1.25/32	5/16-in hex	45/5.1 for #6 - 4
B	Neutral Main Lug				94/10.6 for #3 - 2/0
C	Neutral and Ground Larger Lug	#14 - 2/0	0.55/14	3/16-in hex	45/5.1 for #14 - 8 110/12.5 for #6 - 4 150/17 for #3 - 2/0
D	Neutral and Ground Smaller Lug	#14 - 4	0.55/14	5 mm slotted	20/2.3 for #14 - 10 25/2.8 for #8 - 4
E	EVSE Conductors into terminals on PCB	#2	0.71/18	6 mm slotted or Philips 2	33.6/3.8
F	EVSE Pan to Home Hub Case	NA	NA	Philips 2	25/2.8

Terminal Wire, Gauge Strip Length And Torque Value

G	EVSE Conductors into Bus Lugs on Pan	#2	0.71/18	5/16-in slotted	45/5.1
H	Main Breaker conductor tabs to Home Hub bussing threaded studs	NA	NA	7/16-in socket	48/5.4
I	Main Breaker housing to Home Hub	NA	NA	7mm socket	14/1.6
J	RS485 to Inverter	#23~14	0.4/10	Flat slotted	NA
K	12V/GND to Inverter	#10	0.6/15	Flat slotted	NA

Table 3: Terminal Wire Gauge, Strip Lengths, and Torque Values

Note:

- Torque circuit breaker terminals to values specified on the breakers.
- Terminals other than breaker terminals are suitable for 60/75°C AL/CU wire. Breaker terminals are suitable for wire as marked.

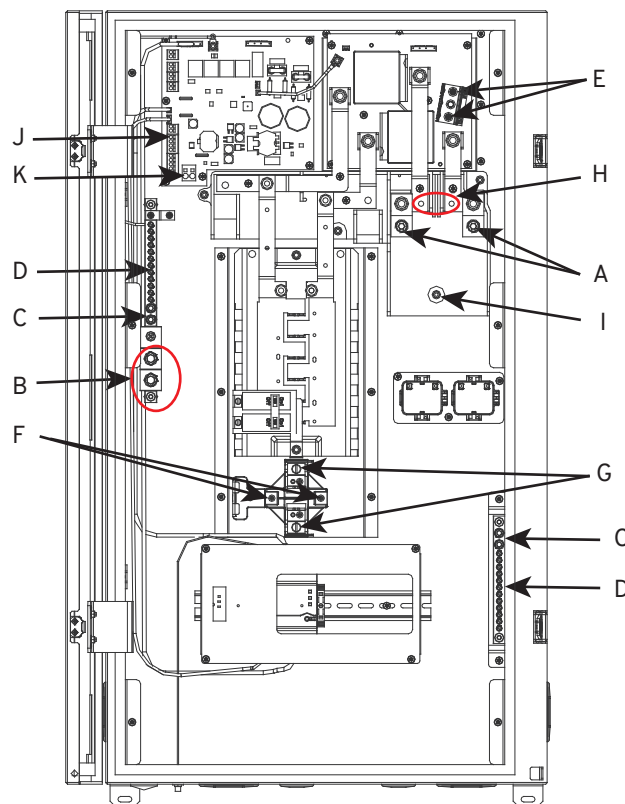

Figure 27: Terminal Indication



WARNING!

This equipment is intended only for charging vehicles not requiring ventilation during charging.

AVERTISSEMENT!

Cet équipement est destiné uniquement à la charge de véhicules ne nécessitant pas de ventilation pendant la charge.



CAUTION!

Risk of electric shock or electric energy-high current levels. Dangerous electric charge is sometimes stored in (identify capacitor) and associated circuitry. Test before touching.

PRUDENCE!

ATTENTION - Risque de choc électrique ou d'énergie électrique - niveaux de courant élevés. Une charge électrique dangereuse est parfois stockée dans (identifier le condensateur) et les circuits associés. Testez-les avant de les toucher.



CAUTION!

Risk Of Electric Shock

Multiple power sources are terminated inside this equipment. Each circuit must be individually disconnected before servicing.

PRUDENCE!

Risque d'électrocution

Plusieurs sources d'alimentation sont terminées à l'intérieur de cet équipement. Chaque circuit doit être déconnecté individuellement avant de procéder à l'entretien.



CAUTION!

GROUNDING INSTRUCTIONS – This unit is to be connected to a grounded, metal, permanent wiring system; or an equipment-grounding conductor is to be run with circuit conductors and connected to equipment-grounding terminal or lead on battery charger. Connections to battery charger shall comply with all local codes and ordinances.

PRUDENCE!

INSTRUCTIONS DE MISE À LA TERRE - Cet appareil doit être raccordé à un système de câblage permanent, métallique et mis à la terre ; ou un conducteur de mise à la terre de l'équipement doit être installé avec les conducteurs du circuit et raccordé à la borne de mise à la terre de l'équipement ou au fil du chargeur de batterie. Les connexions au chargeur de batterie doivent être

conformes à tous les codes et ordonnances locaux.

Wiring steps

2. Grid Power Wire Side Connection.

- Installing 2" conduit into one of the right two conduit holes.
- Route the Utility Grid (N) conductor to the Neutral bar, and the (PE/G) conductor to the Grounding bar, strip ends of conductors, terminate, and torque according to terminal table. Route the Utility Grid L1 and L2 power conductor wires through their respective CT and to the utility lugs, strip ends of conductors, terminate, and torque according to terminal table.
- Verify the connection firmly again.

Note:

- The compatible wiring gauge of (L1, L2, N) for 166A is 3/0, Grounding is 4AWG, should have an ampacity based on UL67, and it is recommended to use 90°C(194 F) copper.
- The polarity of L1 and L2 cross over inside Eaton CSR series main breakers. Installers should exchange the position of CTs as the following image when installing Main Breaker.
- CTs may be relocated or added for specific designs and PCS configurations, install CTs as required per approved plan set.

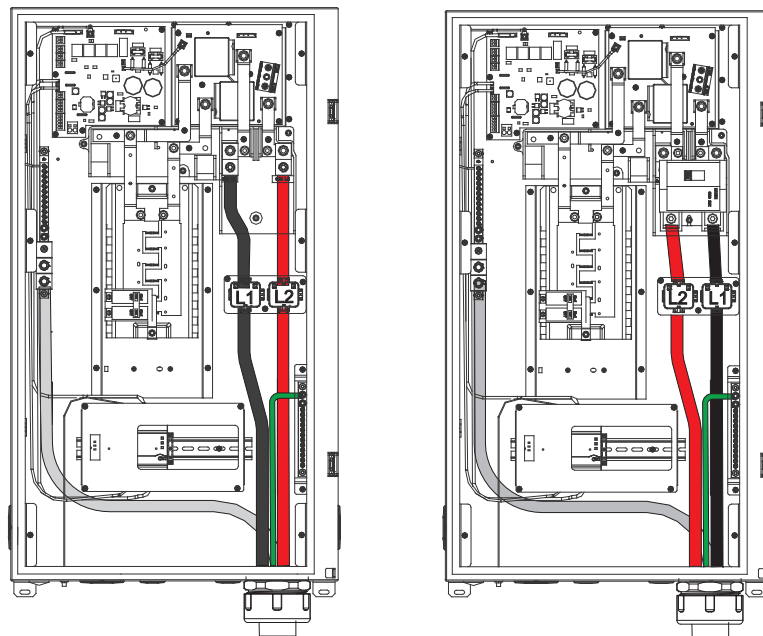

Figure 28: Utility Grid Power Wire Side Connection

- Apply PCS warning labels to CTs during installation. Only in cases where the conductors in the Hub will be greater than or equal to (\geq) AWG 1/0, you must remove the bracket that the CTs are attached to, remove the CTs from the bracket, and then attach the individual CTs to the conductors. (Figure 29)
1. Unscrew the three M4 screws holding the CT bracket to the back wall of the Home Hub.
 2. Connect the appropriate L1 and L2 conductors.
 3. Cut the four small zip ties that secure the CTs to the bracket.
 4. Remove the two CTs from the bracket.
 5. Fit the L1 and L2 CTs around their respective conductors, and attach each to the conductor with one zip tie below and one zip tie above.

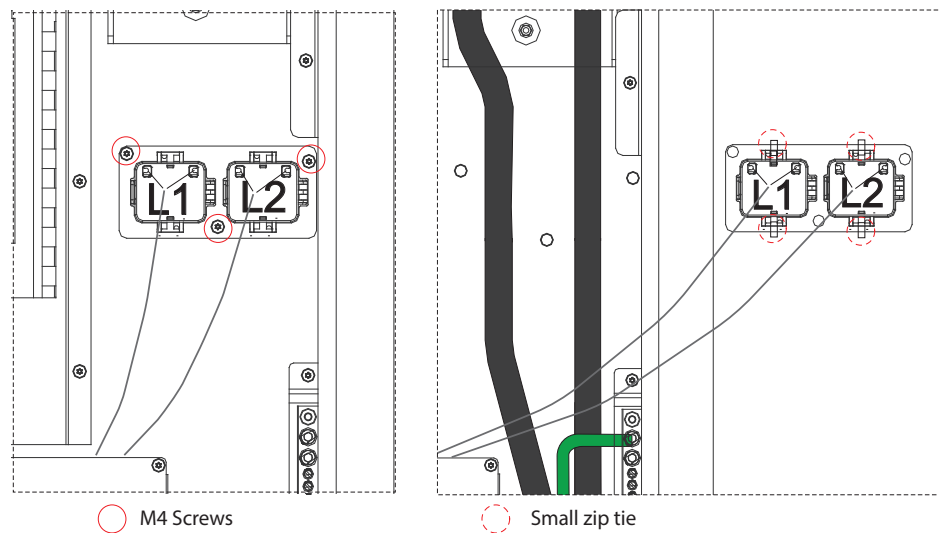

Figure 29: Location of CT bracket screws and zip ties holding CTs to bracket

Wiring steps

3. Optional Non-backup EVSE Side Connection.

- Installing Non-backup EVSE Panel, recommended type is EATON 24INT125B. Fasten the Panel with the two screws attached using a Philips 2 Screwdriver. Recommended torque is 25 in-lbs.
- Connect (L1, L2) conductors from GM Energy Home Hub PCB connector to Non-Backup EVSE Panel Terminal Lugs. Home Hub PCB connector: strip conductors $\frac{1}{2}$ ", terminate L1 conductor into L1 terminal, L2 conductor into L2 terminal, and torque to 35 in-lbs. Non-Backup EVSE panel Terminal Lugs: strip conductors $\frac{3}{4}$ ", terminate L1 into upper lug, L2 into lower lug, and torque to 45 in-lbs.
- Install Breaker. Overcurrent protection rating and conductors shall be sized per approved plan set, not to exceed 100A. Two pole EATON type BR breaker required. Route EVSE (PE/G) conductor to the grounding bar, route the (L1 and L2) power conductors to the breaker, strip and torque the conductors as marked on breaker.
- Verify the connection firmly again.

Wire the EVSE circuit: The largest size EVSE L1/L2 wiring gauge is 3 AWG for 100A OCPD (80A continuous) ampacity based on NEC Table 310.16. The EVSE PE (G) wiring gauge for 100A (80A continuous) is 8 AWG based on NEC article 250.122, and it is recommended to use 90°C(194°F) copper wires. Please check local requirements if there are any additional requirements.

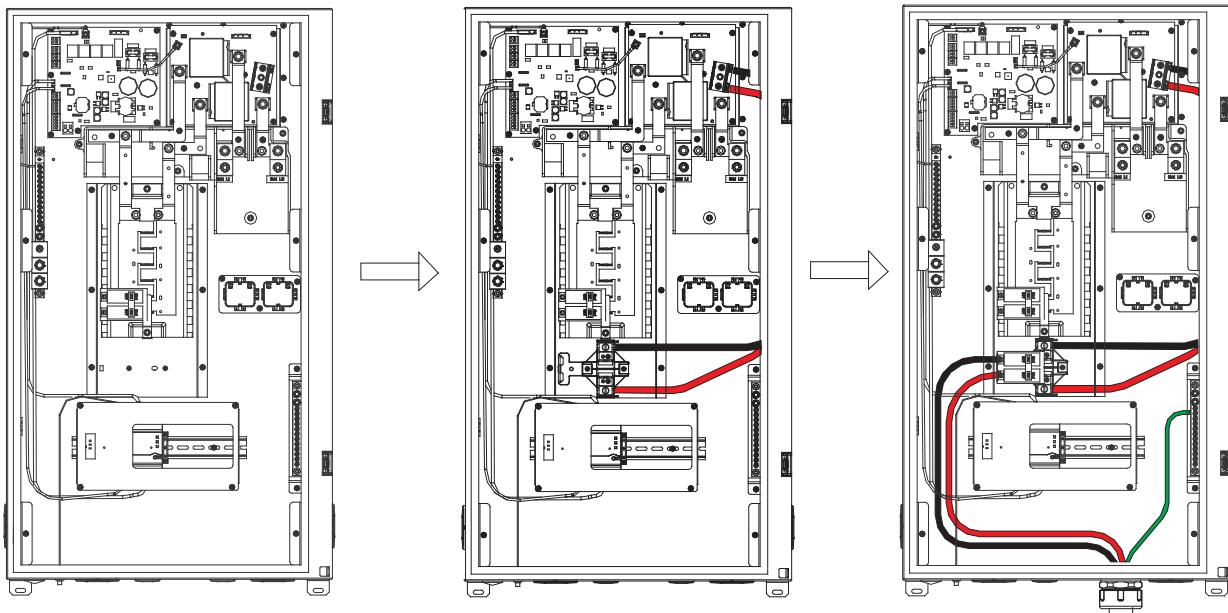

Figure 30: EVSE side wiring

Wiring steps

4. GM Energy Inverter Power Wire Connection.

- Route GM Energy Inverter circuit conductors to the GM Energy Home Hub; Neutral conductor to the (N) bar, Grounding conductor to the (PE/G) bar, strip, terminate, and torque according to the terminal table. Route (L1, L2) power conductors to the factory installed two-pole 60A breaker, strip, terminate, and torque as marked on the breaker. Circuit conductors in Inverter terminate into AC terminal block. Strip conductors and insert into terminal left to right: L1, N, L2. Strip grounding conductor and add spade terminal, then secure to grounding terminal with T-20 torque tool to 16 inlbs.
- Verify the connection firmly again..

Note:

- GM Energy Inverter can only accept 90°C copper wire. Use only 90°C copper wire for GM Energy Inverter wiring.

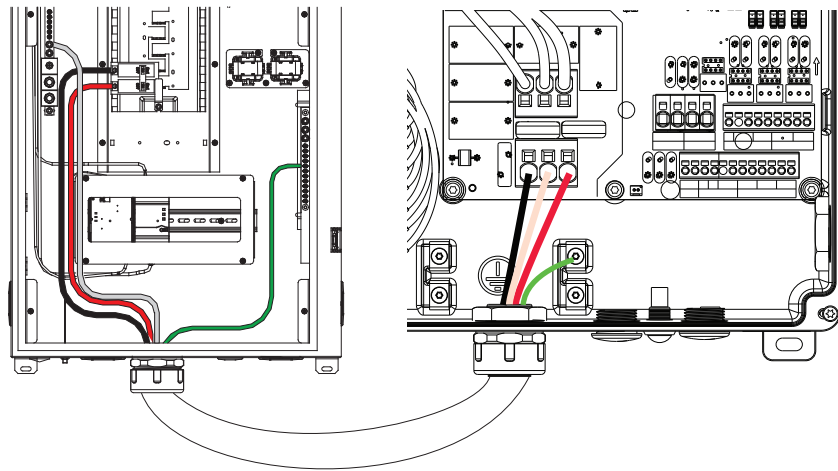

Figure 31: GM Energy Inverter power wire connection

4.6.8 Communication Wiring

GM Energy Home Hub communication connections with GM Energy Inverter connect to the PWB board in the Home Hub, connect the GM Energy Inverter communication cables according to the silk screen printing.

Wiring steps

5. GM Energy Inverter Communication Connection.

- For RS485 A1/B1 and A2/B2, route 14-23 AWG twisted pair conductors to the PWB communication terminals, strip 3/8" and secure the wires into terminals using 1/8" flat blade screw driver to push the spring of each terminal. For 12V Low Voltage DC circuit, route 10-14 AWG conductors to the PWB 12V terminals, strip 7/16" secure the wires into terminals using 1/8" flat blade screw driver to push the spring of each terminal.
- Verify the connection firmly again.

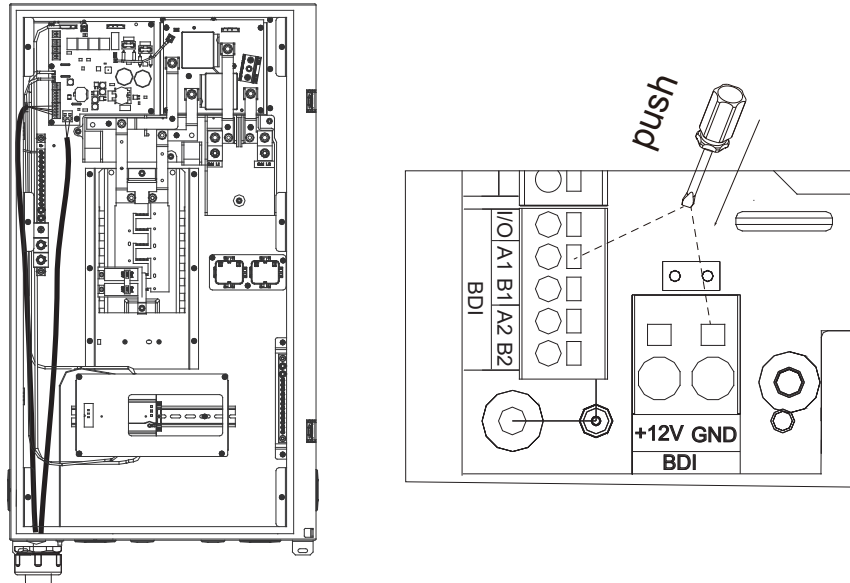

Figure 32: GM Energy Inverter communication wiring

4.6.9 Installation of Optional Meter2

Wiring steps

1. Preparation

Install AC Solar breaker at the down-right corner of the backup load panel. And complete the wiring.

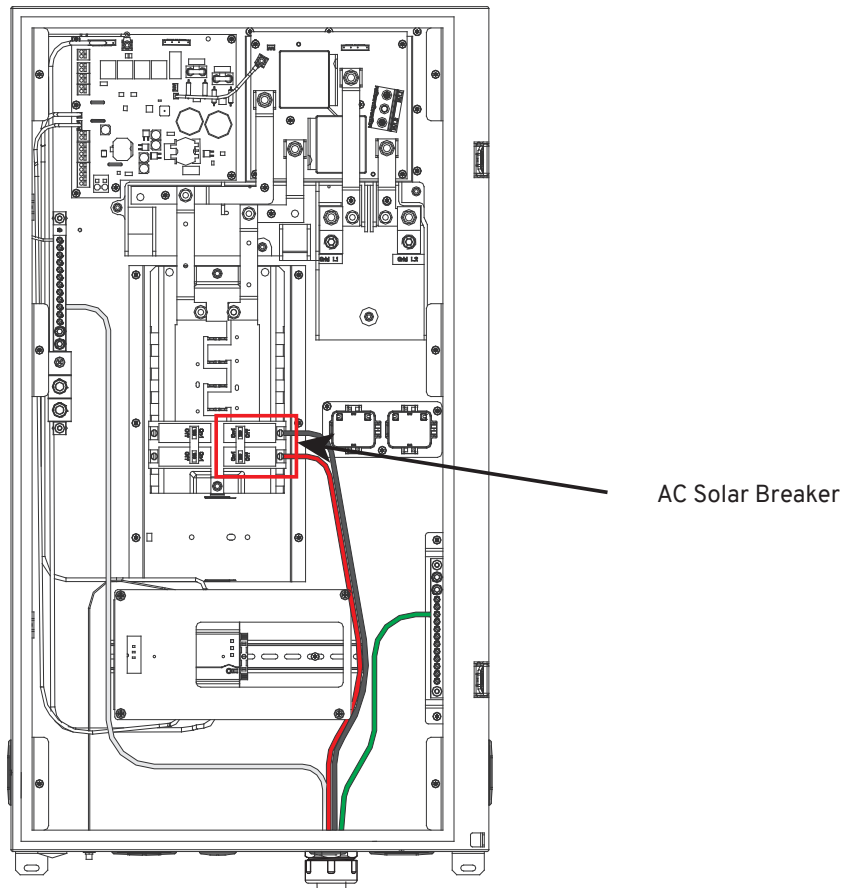

2. Install the Meter2 body

- Remove the meter shelter with a Philips 2 screwdriver. Recommended screw torque is 14 in-lbs.
- Loosen the meter stopper with a 3mm flat screwdriver. Recommended screw torque is 9 in-lbs.
- Install the meter2 and push the clip to lock it.
- Fasten the stopper with a 3mm flat screwdriver. Recommended screw torque is 9 in-lbs.

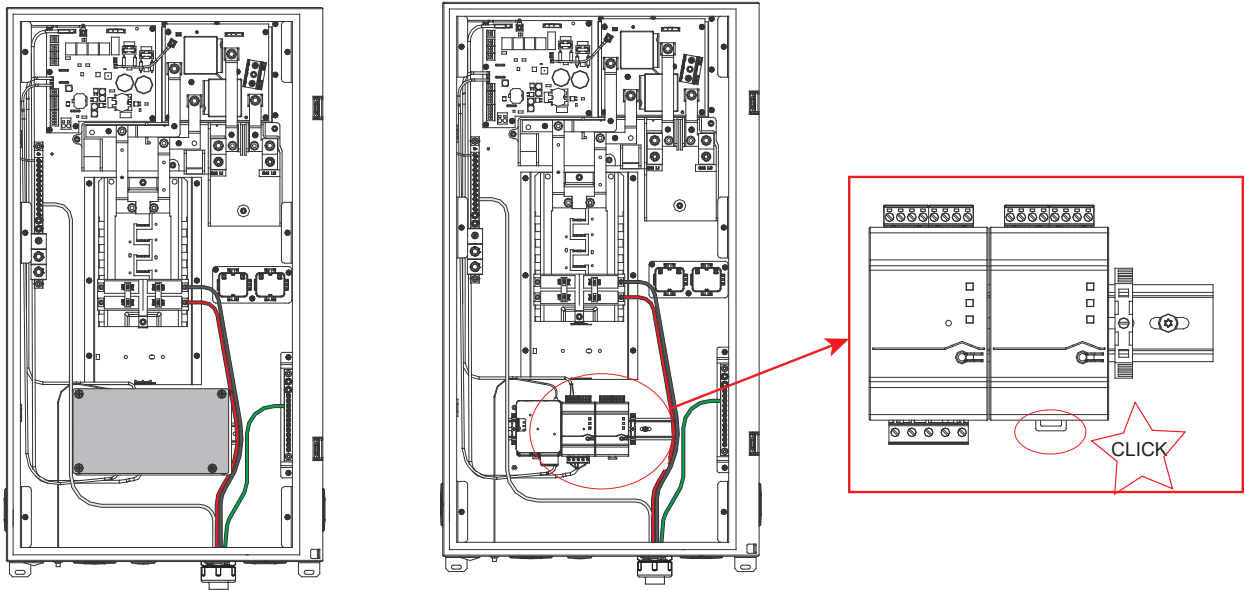

3. Wiring the meter2

- Install the meter2 L1/L2/N/PE wire, connect the wires one by one according to the markings of control board and meter2. Wire Gauge: 14-23AWG (recommended 18AWG), twisted pair, 90°C, 600V copper wiring.
- * Tools: 1/8" flat blade head bit, Wire cutters / strippers

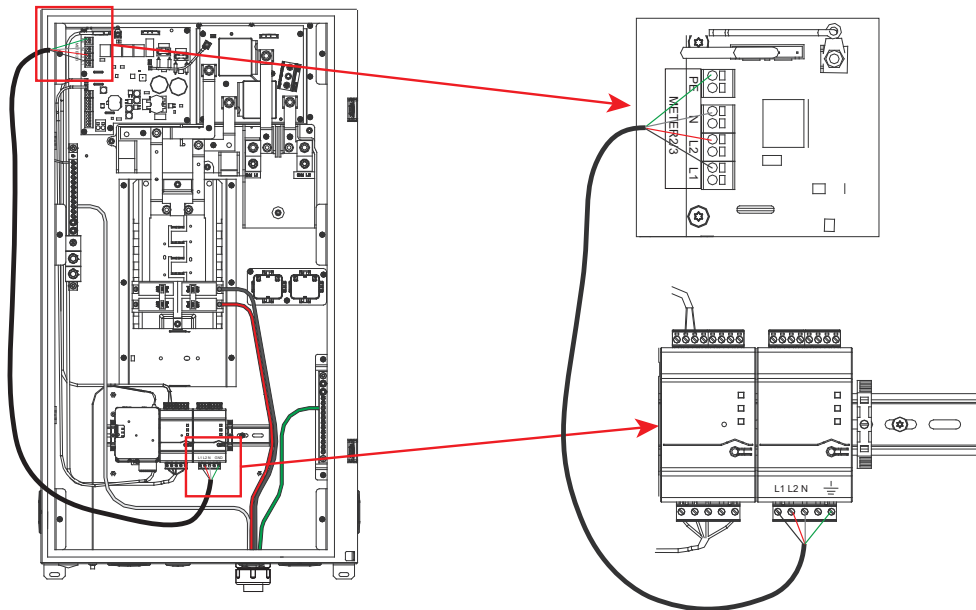

- Install the meter2 RS485 wire, connect the wires one by one according to the markings of control board(Meter2 A2/B2) and meter2(A+/B-). Wire Gauge: 14-23AWG (recommended 18AWG), twisted pair, 90°C, 600V copper wiring.
- * Tools: 1/8” flat blade head bit, Wire cutters / strippers

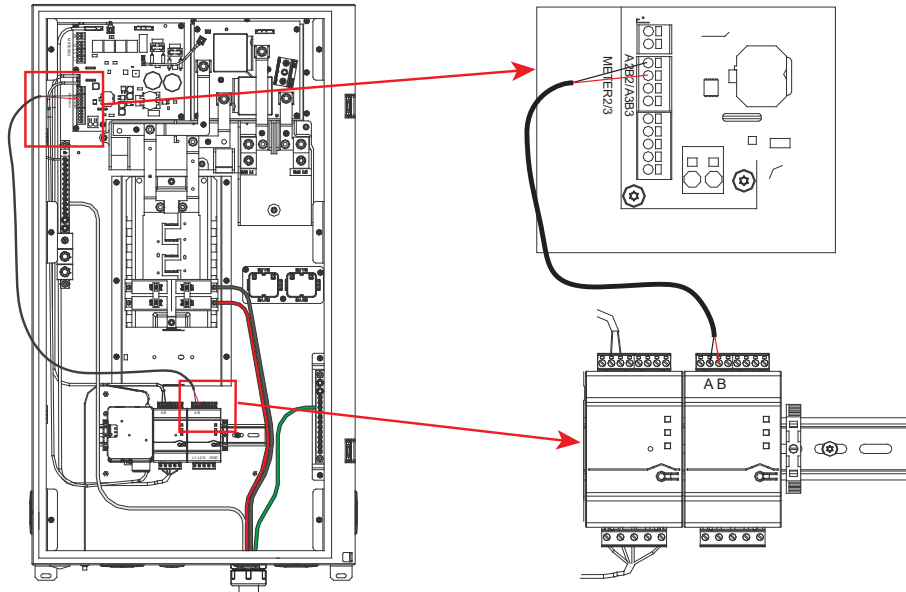

4. Install the meter2 CTs

- Clip one CT body(CT wire with red tube) to line AC Solar L1 and clip the other CT body(CT wire with red tube) to line AC Solar L2. Be careful of the arrow direction of the CT, point to the AC Solar breaker from outside as the picture below.

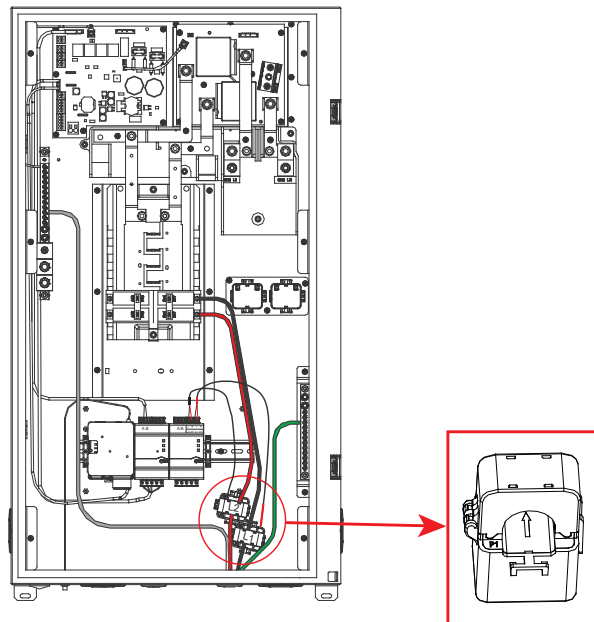

5. Install the meter shelter.

Install the meter shelter with a Philips 2 screwdriver. Recommended screw torque is 14 in-lbs.

6. Commissioning

Please check the status of meter2, referring to the commissioning section of the system installation manual.

4.6.10 Final Inspection



WARNING!

Only certified personnel with adequate Personal Protective Equipment(PPE) shall perform work around live circuits. See system manual on additional PPE requirements.

AVERTISSEMENT!

Seul le personnel certifié disposant d'un équipement de protection individuelle (EPI) adéquat doit effectuer des travaux à proximité de circuits sous tension. Voir le manuel du système pour les exigences supplémentaires en matière d'EPI.

1. Confirm that all connections are correct, properly grounded, and secure torqued and paint marked.
2. Verify wiring, voltage, and phase polarity by energizing the equipment, closing breakers, and recording power readings with digital multi-meter. De-energize equipment.
3. Install the door assembly by affixing it to the hinges. Re-install the deadfront cover and secure the six T-20 head screws to 18 in-lbs. with torque tool.
4. Only after fully replacing the deadfront assembly, restore power.
5. Secure the panel door closed with the hasps at the right sides of the panel door.

5 PCS CRD

Scenario A1: Placing metering at service entrance - Partial Home Backup

Place the PCS meter at the grid connection to real time monitor the grid current. GM Energy Inverter can manage to control the output power based on the calculation results of load condition if it is over 80% of busbar rating. At the moment of the current hits 80%, the GM Energy Inverter stops providing power.

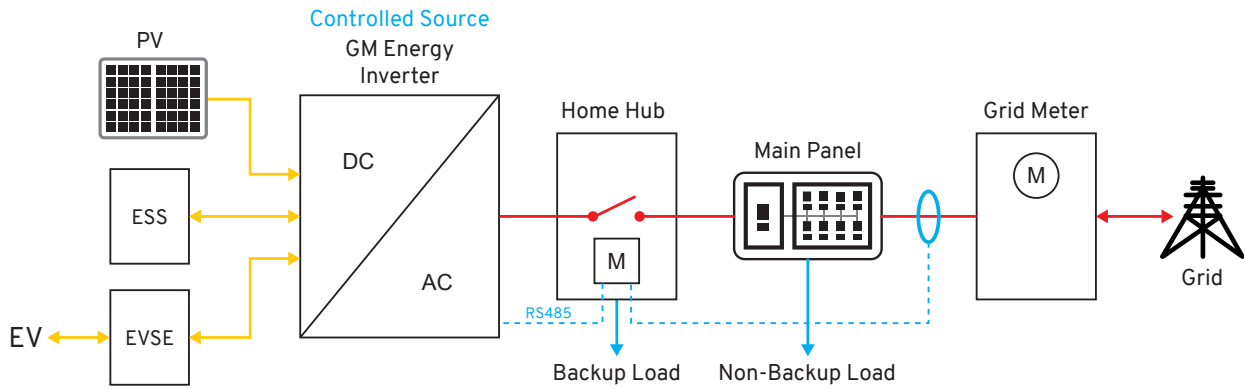

Scenario A2: Placing metering at service entrance - Whole Home Backup

For whole Home Backup solution, the CT is left in the factory-installed location in Home Hub. For busbar protection, the same control logic as Scenario A1.

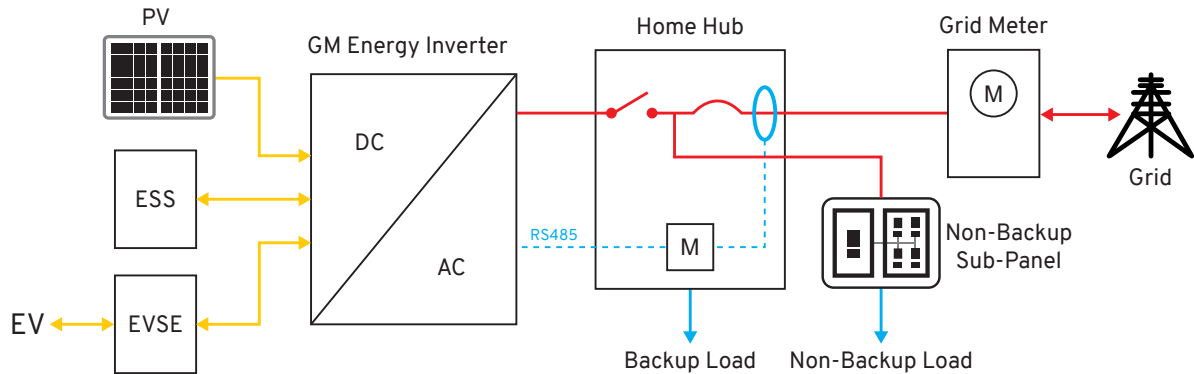

Scenario B: Placing metering on GM Energy Home Hub output

Place the PCS meter at the output of HomeHub in stead of at the grid connection. Then limit the power that can flow backwards through the CTs (out of the Home Hub and into the MSP). Left in the factory-installed location in the Home Hub to reduce measurement error, install error, etc. The disadvantage is it may limit the amount of solar that can be exported back to the grid or consumed in the main panel.

Max. Home Hub output current allowed past PCS CT = 120% busbar - MSP breaker

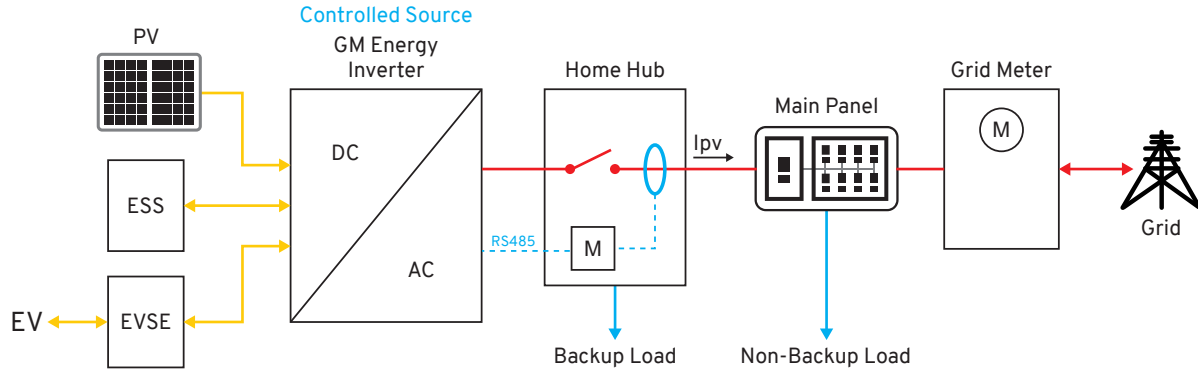

Scenario C: A PCS to limit the GM Energy Inverter output with no external metering

The GM Energy Inverter need to be certified with an additional PCS mode of Single power source output limit that limits its output current to a defined output maximum without using an external meter. The maximum output should be settable to zero.

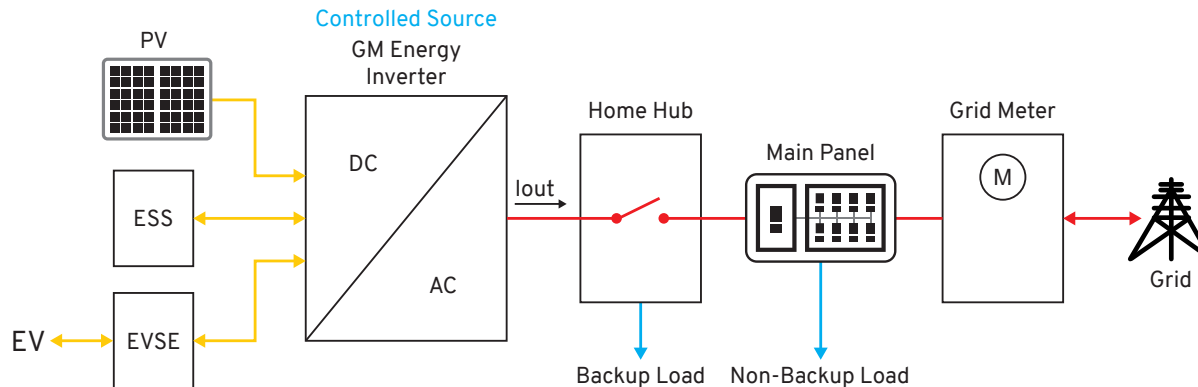

Scenario D1: Partial Home Backup with AC Solar – The existing solar at backup load panel

For AC coupled system, two meters are required to monitor both grid current and AC solar current. Based on these monitoring current, the PCS integration in GM Energy Inverter can manage to control its output power per the calculation results of busbar loading if it is over 80% of busbar rating. In this case the existing solar system would manage the busbar current as it has previously meet 120% rule.

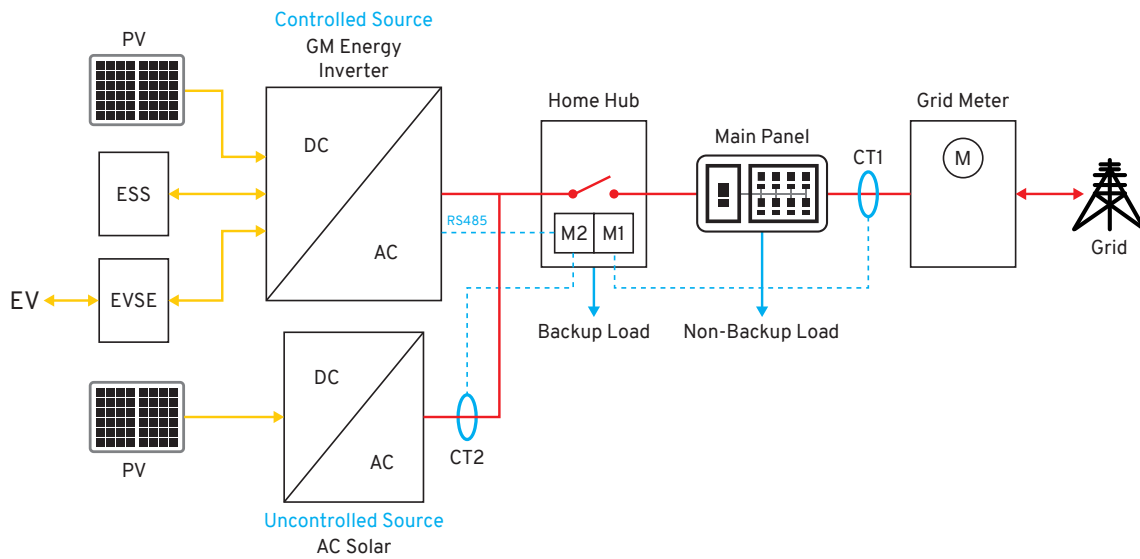

Scenario D2: Partial Home Backup with AC Solar – The existing solar at MSP

For busbar protection, the same control logic as Scenario D1.

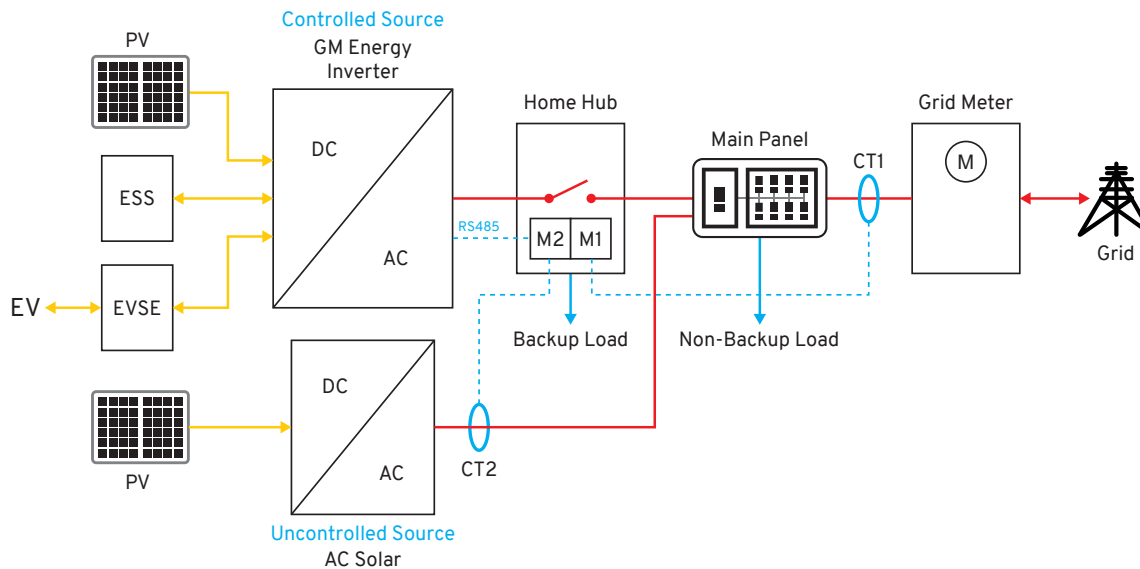

Scenario D3: AC Coupled System integrated PCS – Whole Home Back

For busbar protection, the same control logic as Scenario D1

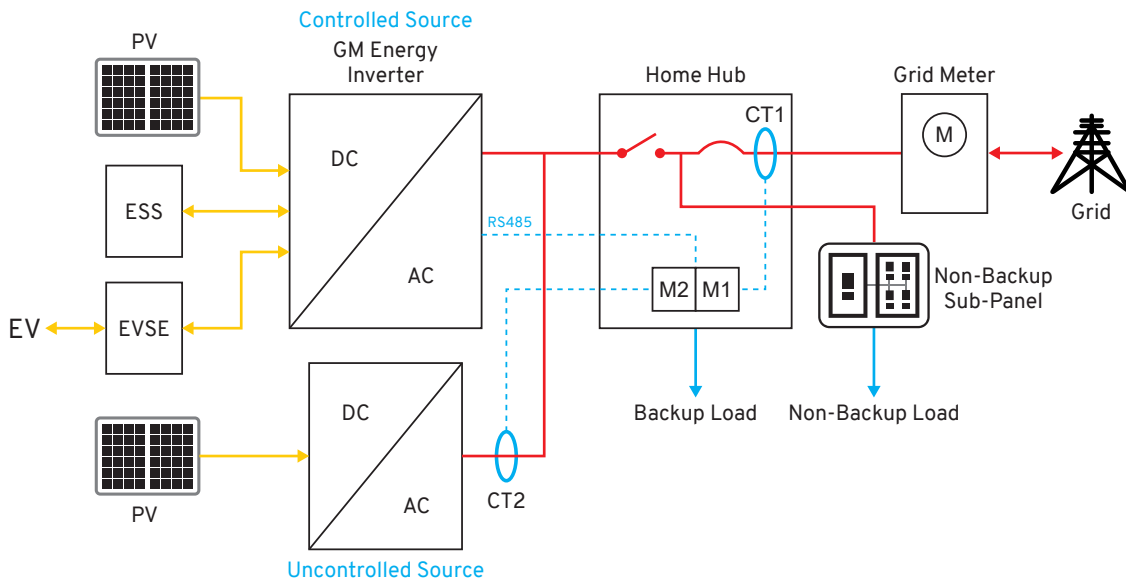

Scenario E: Partial Home Backup with existing solar at MSP

- Placing Metering on GM Energy Home Hub Output

Max. Home Hub output current allowed past PCS CT = 120% busbar – MSP breaker – AC Solar

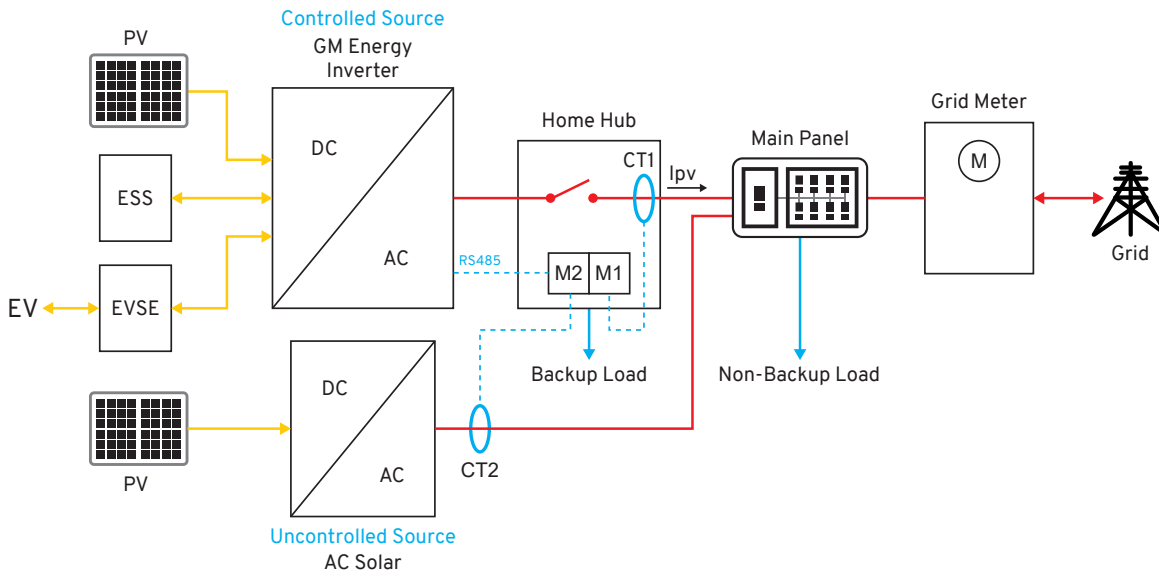

6 COMMISSIONING THE V2H SYSTEM



WARNING!

Read all of these instructions, cautions, and warnings for the GM Energy Inverter and Home Hub.

AVERTISSEMENT!

Lisez l'ensemble de ces instructions, précautions et avertissements concernant l'onduleur GM energy et le Home Hub.



WARNING!

Installation and commissioning must be performed by Qualified Personnel that are licensed and/or satisfied state and local jurisdiction regulations in accordance with local, state, and National Electrical Code ANSI/NFPA 70 requirements.

AVERTISSEMENT!

L'installation et la mise en service doivent être effectuées par du Personnel Qualifié, titulaire d'une licence et/ou satisfaisant aux réglementations de l'État et de la juridiction locale, conformément aux exigences locales, de l'État et du Code national de l'électricité (ANSI/NFPA 70).



WARNING!

Verify that the dedicated 2-pole 240 Vac circuit breaker in the building electrical service panel is turned-off.

AVERTISSEMENT!

Vérifiez que le disjoncteur à 2 circuits de 240 Vca du tableau d'alimentation électrique du bâtiment est mis hors tension.



NOTICE!

Disconnect in the "OFF" position, verify the PV input polarity once more simply by carefully using a 600 V, DC rated digital volt meter and probing the positive (+) and negative (-) PV array connections.

AVIS!

Débranchez l'appareil lorsqu'il est éteint (« OFF ») puis vérifiez à nouveau la polarité de l'entrée PV en utilisant simplement avec précaution un voltmètre numérique de valeur nominale de 600 Vcc et en prélevant les mesures au niveau des connexions positive (+) et négative (-) du groupe solaire PV.

6.1 Commissioning App

The PowerShift Install App is a mobile application to communicate with V2H system for real-time status monitoring, system mode management, RMA request upload and daily maintenance.

Please refer to the website or QR code below for how to access and download the App.



<https://gmenergy.gm.com/home/resources-and-support>

7 COMMISSIONING THE SYSTEM

Please refer to the system installation guide for details on commissioning the system. The system install guide, install app, and other installer support resources are available at the website below.

<https://gmenergy.gm.com/for-home/installation-support>

7.1 Buzzer Indication

There is a alarm system in GM Energy Home Hub, it will response when some errors happen.

Buzzer Indication		
Error	Status Clear	Alarm
RELAY ERROR	Within 5 s~2 h automatically clear	500 ms/1 s beeping
COMM ERROR	Auto recovery after fault clear	1 s/10 s beeping
PCS OFF ERROR	Auto recovery after fault clear	1 s/10 s beeping
OTP ERROR	Auto recovery after fault clear	1 s/10 s beeping

8 PRODUCTION INFORMATION



NOTICE!

All production information is provided for orientation purposes only. The measuring devices and meters provided by the electricity supply company are the authoritative source of information for invoicing.

AVIS!

Toutes les informations de production ne sont fournis qu'à titre d'orientation. Les appareils de mesure et les compteurs fournis par la société de distribution d'électricité constituent la source officielle de la facturation.

9 REPAIR



DANGER!

Danger of death from hazardous voltage.

Hazardous voltage is applied to the V2H system during operation. Hazardous voltage is still present 5 minutes after all power sources have been disconnected.

Do not attempt to open, disassemble, repair, tamper with, or modify the equipment. The equipment contains no user-serviceable parts. Contact the installer who installed the equipment for any repairs. Opening the cover will void the limited warranty.

DANGER!

Risque de mort par une tension dangereuse.

La tension dangereuse est appliquée à l'onduleur solaire pendant le fonctionnement. Une tension dangereuse est toujours présente 5 minutes après que toutes les sources d'alimentation ont été débranchées.

N'essayez pas d'ouvrir, de démonter, de réparer, d'altérer ou de modifier l'appareil. L'équipement ne contient aucune pièce réparable par l'utilisateur. Pour toute réparation, contactez l'installateur qui a installé l'équipement. L'ouverture du couvercle annule la garantie limitée.



NOTICE!

The Home Hub contains no components that are to be maintained by the operator or installer.

AVIS!

Le Home Hub ne contient aucun composant devant être entretenu par l'opérateur ou l'installateur.

10 DECOMMISSIONING, TRANSPORT, STORAGE, DISPOSAL



DANGER!

Danger of death or severe injuries from dangerous voltage

Disconnect the Home Hub from the grid before removing or inserting the AC connector. Follow local utility/jurisdiction requirements to disconnect/lock-out.

DANGER!

Danger de mort ou de blessures graves par une tension dangereux

Déconnecter l'onduleur solaire du réseau électrique avant de retirer ou d'insérer le connecteur AC. Respecter les exigences des services publics locaux et des autorités compétentes en matière de déconnexion/verrouillage.



DANGER!

Improper servicing of the equipment or its components may result in a risk of shock, fire or explosion. To reduce these risks, disconnect all wiring before attempting any maintenance or cleaning.

Always de-energize the equipment before servicing. While connectors are rated for disconnect under load, it is best practice to de-energize before disconnecting.

DANGER!

Un mauvais entretien de l'appareil ou de ses composants peut entraîner un risque d'électrocution, d'incendie ou d'explosion. Pour réduire ces risques, débranchez tous les câbles avant de procéder à l'entretien ou au nettoyage.

Mettez toujours l'équipement hors tension avant de procéder à l'entretien. Bien que les connecteurs soient conçus pour être déconnectés sous charge, il est préférable de les mettre hors tension avant de les déconnecter.



WARNING!

Danger of injury due to heavy weight

The GM Energy Home Hub is heavy (see "11.2 Technical data"). Incorrect handling can lead to injuries.

The GM Energy Home Hub must be lifted and carried by two people.

AVERTISSEMENT!

Risque de blessure en raison du poids lourd

Le GM Energy Home Hub est lourd (voir «11.2 Caractéristiques techniques»). Une mauvaise manipulation peut entraîner des blessures.

Le GM Energy Home Hub doit être soulevé et porté par deux personnes.

10.1 Decommissioning

1. Switch off all the breakers to be free of voltage.
2. Remove all cables from the GM Energy Home Hub.
3. Unscrew the Home Hub from the wall bracket.
4. Lift the Home Hub from the wall bracket.

10.2 Packaging

Use the original packaging or packaging of the same quality.

10.3 Transport

Always transport the GM Energy Home Hub in the original packaging or packaging of the same quality.

10.4 Storage

Always store the GM Energy Home Hub in the original packaging or packaging of the same quality. Recommended storage condition: temperature 5°C ~ 35 °C, humidity less than 70%RH. Packaged equipment must not be stored in temperatures beyond -40 °C to 60 °C.

10.5 Disposal

Dispose of the GM Energy Home Hub in a technically appropriate manner according to the legal requirements of your country.

11 CERTIFICATE AND TECHNICAL DATA

11.1 Certificate

Please check at: <https://www.csagroup.org/testing-certification/product-listing> for the most recent certificates.

11.2 Technical Data

Model Name	GM Energy Home Hub e1.200
GENERAL ELECTRICAL SPECIFICATION	
Supported backup configurations	Whole home backup / Partial home backup (up to 200 A service)
Maximum main breaker rating	200 A
Maximum continuous current	166 A
Nominal allowed service voltage	120/240 V 60 Hz split phase
Short circuit rating	Up to 10 kA
Standby power consumption	<8 W
Overcurrent protection device allowed ¹⁾	100-200 A/ service entrance rated
AC metering	ANSI C12.20, Class 0.5
Load/ Generation Breaker	Refer to installation guide for available spaces
Overvoltage Category	OV IV
GENERAL SPECIFICATION	
Operating temperature range	-4 °F to 122 °F (-20 °C to 50 °C)
Humidity	0% to 95%
Maximum operating altitude	9,843 ft (3,000 m) above sea level
Installation	Wall mounting
Enclosure protection rating	Type 3R
Connectivity	Ethernet, WiFi
MECHANICAL DESIGN	
Dimensions (W x H x D)	20.5 x 35.8 x 7.56 in (520 x 910 x 192 mm)
Weight	45.2 lbs (20.5 kg)
Cooling	Natural convection
Compatible wiring gauge	AWG 10 to AWG 4/0
WARRANTIES AND CERTIFICATIONS	
Certification and Compliance	UL 1741, CSA-C22.2 No. 107.1-16, UL 67, UL 869A, FCC Part 15 class B
PCS	UL 1741 PCS CRD, NEC 705.13
Warranty	10 years

¹⁾ Recommended service-rated circuit breaker type must be installed.

11.3 FCC Compliance Information

GM Energy Home Hub, complies with Part 15 of the FCC Rules. Operation is subject to the following conditions:

1. **This device may not cause harmful interference**
2. **This device must accept any interference received, including interference that may cause undesired operation.**

Note: This equipment has been tested and found to comply with the limits for a Class B digital device, pursuant to part 15 of the FCC Rules. These limits are designed to provide reasonable protection against harmful interference in a residential installation. This equipment generates, uses and can radiate radio frequency energy and, if not installed and used in accordance with the instructions, may cause harmful interference to radio communications. However, there is no guarantee that interference will not occur in a particular installation. If this equipment does cause harmful interference to radio or television reception, which can be determined by turning the equipment off and on, the user is encouraged to try to correct the interference by one or more of the following measures:

Reorient or relocate the receiving antenna

Increase the separation between the equipment and the receiver

Connect the equipment into an outlet on a circuit different from that to which the receiver is connected.

Consult the dealer or an experienced radio/TV technician for help.

The user is cautioned that changes or modifications not expressly approved by GM Energy could void the user's authority to operate this equipment.

Please contact GM Energy Customer Support Center at 1-833-64POWER for more information.

11.4 Canada Compliance Information

This Class B digital apparatus complies with Canadian ICES-003.

12 LIMITED WARRANTY EXCLUSIONS

For more information about the limited warranty and assistance with warranty repairs or returns you may contact our GM Energy Support Center at 1-833-64POWER or go to <https://gmenergy.gm.com/for-home/here-to-help>. Failure to strictly comply with this GM Energy Home Hub Installation and Operation Manual voids any such warranty.

13 APPENDIX

Gateway available for Home Hub

14 GLOSSARY

AC

Abbreviation for “Alternating Current”.

AFCI

Abbreviation for “Arc-Fault Circuit Interrupters”.

AHJ

Abbreviation for “Authority Having Jurisdiction”.

Anti-islanding protection

This is a unit for grid monitoring with assigned switching elements (anti-islanding protection) and is an automatic isolation point for small power generation systems (to 30 kWp).

Basic Insulation

Insulation to provide basic protection against electric shock.

CEC

Abbreviation for the California Energy Commission

CEC Efficiency

CEC Efficiency is the California Energy Commission Efficiency rating, a performance rating for modules and inverters based on the real environment that a system will be in.

CSA

Abbreviation for the Canadian Standards Association.

DC

Abbreviation for “Direct Current”.

EGC

Equipment Grounding Conductor

EMC

The Electro-Magnetic Compatibility (EMC) concerns the technical and legal basics of the mutual influencing of electrical devices through electromagnetic fields caused by them in electrical engineering.

EVSE

electrical vehicle supply equipment

FCC

FCC is the abbreviation for Federal Communications Commission.

Galvanic isolation

No conductive connection between two component parts.

GND

Ground

IEEE

The Institute of Electrical and Electronics Engineers or IEEE (read I-Triple-E) is an international non-profit, professional organization for the advancement of technology related to electricity.

IMI

Isolation Monitor Interrupter

Initialization

Under initialization (cf. English to initialize) is understood the part of the loading process of a program, in which the storage space required for the execution (e.g. variable, code, buffers ...) for the program is reserved and is filled with initial values.

ISC

Short Circuit Current

Local utility company

A local utility company is a company which generates electrical energy and distributes it over the public grid.

MPP

The Maximum Power Point is the point on the current-voltage (I-V) curve of a module, where the product of current and voltage has its maximum value.

NEC

The National Electrical Code (NEC), or NFPA 70, is a United States standard for the safe installation of electrical wiring and equipment.

Nominal power

Nominal power is the maximum permissible continuous power output indicated by the manufacturer for a device or a system. Usually the device is also optimized so that the efficiency is at its maximum in case of operation with nominal power.

Nominal current

Nominal current is the absorbed current in case of electrical devices if the device is supplied with the nominal voltage and yields its nominal power.

PE

In electric systems and cables a protective earth conductor is frequently employed. This is also called grounding wire, protective grounding device, soil, grounding or PE (English “protective earth”).

Photovoltaics (abbr.: PV)

The conversion of PV energy into electrical energy.

The name is composed of the component parts: Photos - the Greek word for light - and Volta - after Alessandro Volta, a pioneer in electrical research.

Power dissipation

Power dissipation is designated as the difference between absorbed power and power of a device or process yielded. Power dissipation is released mainly as heat.

PV cell

PV cells are large-surface photodiodes which convert light energy (generally sunlight) into electrical energy. This comes about by utilization of the photoelectric effect (photovoltaics).

PV generator

System comprising of a number of PV modules.

PV module

Part of a PV generator; converts PV energy into electrical energy.

RJ45

Abbreviation for standardized eight-pole electrical connector connection. RJ stands for Registered Jack (standardized socket).

RS485 (EIA485)

Differential voltage interface on which the genuine signal is transmitted on one core and the negated (or negative) signal on the other core.

Separate grid system

Energy supply equipment which is completely independent of an interconnected grid.

Solar inverter

is an electrical device which converts DC direct voltage into AC voltage and/or direct current into alternating current.

String

Designates a group of electrical PV modules switched in series.

String solar inverter (solar inverter concept)

The PV generator is divided up into individual strings which feed into the grid over their own string solar inverters in each case. In this way, the installation is considerably facilitated and the gain decrease, which can arise from the installation or from different shading conditions of the PV modules, is considerably reduced.

UL

Stands for Underwriters Laboratory, a non-profit organization that sets standards for different product categories and tests products to make sure they meet the standards.

VOC

Open Circuit Voltage



Home Hub

