



# PowerBank

installation manual containing instructions and safety information

The information included in this installation manual is accurate at the time of publication.

However, this manual is subject to change without prior notice. Please refer to the website for the latest version.

※ <https://gmenergy.gm.com/home/resources-and-support>

Please note that the images shown are for illustration purposes only to help explain system configuration concepts and installation instructions, and may not be exact representations of the product. All references to the “Battery Pack” are to the GM Energy PowerBank product.

## Contents

<b>1 Safety</b> .....	<b>4</b>
1.1 Qualified personnel .....	4
1.2 Safety Symbols and Safety Words .....	5
1.2.1 Safety Symbols on the Battery Pack .....	5
1.2.2 Safety Words in the Installation Manual .....	6
1.3 Safety instructions and warnings .....	6
1.3.1 Response to emergency situations .....	9
1.4 Label .....	10
1.4.1 Warning label .....	11
1.4.2 Product label .....	12
1.4.3 Traceability label .....	12
1.4.4 Mac address label .....	12
1.4.5 User guide and warranty label .....	12
<b>2 Product Introduction</b> .....	<b>13</b>
2.1 Technical data .....	13
2.1.1 Specification .....	13
2.2 Short Circuit Current & Duration .....	15
2.3 Arc Flash Protection Calculation .....	15
2.4 Features .....	17
2.5 Maintenance .....	17

<b>3</b>	<b>Installation &amp; Uninstallation</b>	<b>18</b>
3.1	Installation Requirements	18
3.1.1	Package Contents	18
3.1.2	Basic Lifting Guide	20
3.1.3	Unboxing the Battery Pack	21
3.1.4	Installation locations	23
3.1.5	System clearance	24
3.1.6	Required Tools	25
3.1.7	Installation Instructions for the Battery Pack	26
3.2	Cable connections	37
3.2.1	Information of cable connection	37
3.2.2	Guide for cable connection and setting the Dip switch	38
3.3	Uninstallation	41
<b>4</b>	<b>Commissioning</b>	<b>46</b>
4.1	LED indicators	46
4.2	Powering up the Battery Pack	47
4.3	Shutting off the Battery Pack	47
<b>5</b>	<b>Troubleshooting</b>	<b>48</b>
5.1	Post-Installation Check List	48
5.2	Troubleshooting Guidelines	49
<b>6</b>	<b>Appendix</b>	<b>51</b>
6.1	Single Pack Installation	51
6.2	Parallel Installation	51
6.2.1	Communication port	51
6.2.2	Power port	53
<b>7</b>	<b>Contact information</b>	<b>55</b>

# 1 Safety

The Installation Manual contains important safety instructions and warnings.

## WARNING

Read all safety warnings and all instructions prior to installation and use. Where the Battery Pack is being installed alongside a power port and inverter, you must also read all safety warnings and instructions in the guides for the power port and inverter .

## WARNING

Only Qualified Personnel should install, uninstall, service or repair the Battery Pack.

## WARNING

Failure to read and observe the safety instructions in this Installation Manual and other system guides can result in accidents which can lead to serious bodily injury and/or death as well as serious property damage.

## 1.1 Qualified personnel











The handling, installation and uninstallation tasks and procedures described herein are intended for use by qualified personnel only. Qualified personnel are trained and qualified electricians or installers who have familiarized themselves with the Installation Manual and satisfy all of the following requisites:

- Knowledge of the safe, functional principles and operation of grid-tied and non-grid tied energy systems.
- Knowledge of the dangers and risks associated with installing and using electrical devices and acceptable mitigation methods.
- Knowledge of and adherence to this guide all safety precautions.
- Obtains all qualifications specified in product warranty file. This includes but is not limited to
  - : GM Energy PowerBank certification approved by GM Energy.
  - : Knowledge of local electrical safety codes standards, i.e., NEC.
  - : Electrical license for battery installation required by the country or state.
- Repairing the Battery Pack by disassembly is possible only at the GM Energy Service Center or by a person with maintenance authorization from GM Energy.



## 1.2 Safety Symbols and Safety Words

### 1.2.1 Safety Symbols on the Battery Pack

	Caution, risk of electric shock
	Do not place or install the product near flammable or explosive materials
	Install the product out of reach of children
	Read the Installation Manual before starting installation and operation
	Heavy weight may cause serious injury to the back
	Do not dispose of the product with household wastes The crossed-out wheeled bin symbol indicates that the Battery Pack should be recycled or disposed of separately from household waste according to local laws and regulations and taken to local collection points where available. Please recycle or dispose of the product at end-of-life in accordance with local requirements.
	The Battery Pack should be disposed of at a proper facility for environmentally safe recycling.
	Disconnect the equipment before carrying out maintenance or repair
	Observe precautions for handling electrostatic discharge sensitive devices
	Protective Class 1
	Caution, risk of electric shock, energy storage timed discharge

## 1.2.2 Safety Words in the Installation Manual



**DANGER**

indicates an immediately hazardous situation which, if not avoided, will result in death or serious injury



**WARNING**

indicates a potentially hazardous situation which, if not avoided, could result in death or serious injury



**CAUTION**

indicates a potentially hazardous situation which, if not avoided, could result in minor injury



**NOTICE**









indicates a situation which, if not avoided, could lead to damage to the product or other property damage









## 1.3 Safety instructions and warnings

For safety reasons, installers are responsible for familiarizing themselves with the contents of this document and all warnings and instructions before performing installation and servicing.

- Only qualified personnel should install, uninstall, handle, service or repair the Battery Pack. Do not attempt installation, service or repair if not qualified according to the criteria in Section [1.1 Qualified Personnel](#) of this Installation Manual.
- Comply with all NFPA guidelines.
- The safety and performance of the Battery Pack can be affected if it is exposed to abuse, damage or negligence, before or after it is put into operational use. Therefore, it is important that it is installed and maintained in accordance with the instructions and safety warnings in this Installation Manual.
- Damaged batteries are dangerous and must be handled with extreme caution. They are not fit for use and may pose a danger to people or property. If the Battery Pack seems to be damaged, do not proceed with installation and contact GM Energy Support Center or your distributor.
- Over-voltages or wrong wiring can damage the Battery Pack and cause combustion which can be extremely dangerous.
- Any type of product breakdown may lead to a leakage of electrolytes or flammable gas.
- Avoid installing the Battery Pack where flammable materials are stored.
- Do not install the Battery Pack in places where explosive gas or chemicals are present.
- During installation and wiring of the Battery Pack, the utility grid and solar input must be disconnected from the inverter.
- Wiring for Battery Pack installation must only be carried out by qualified personnel.
- Battery Pack installation must only be carried out by qualified personnel.
- The Battery Pack should only be serviced by qualified personnel.
- The electronics inside the Battery Pack are vulnerable to electrostatic discharge.
- Be sure to be electrically grounded before handling the Battery Pack.
- If the Battery Pack needs to be stored before installation, you should ensure that it is stored in a manner that satisfies all the safety requirements and general requirements specified in this installation manual.
- Check the Battery Pack after you receive it. Do not install the Battery Pack if it has been damaged.

- Read the label with Warning Symbols and Precautions, which are visible under the Front Cover (see Section 1.4.1 Warning Label!).

	<ul style="list-style-type: none"> <li>• Do not expose the Battery Pack to open flame or other heat sources.</li> </ul>
	<ul style="list-style-type: none"> <li>• Do not place the Battery Pack near flammable materials such as any liquid filled petroleum containers, compressed natural gas/ propane/ welding fuel tanks, natural gas supply lines, oxygen tanks, swimming pool chemicals, home furnaces, or boilers, gas cans/kerosene cans, kerosene/oil powered portable heaters, oil rags, fuel oil tanks, or garbage bins.</li> </ul>
	<ul style="list-style-type: none"> <li>• Do not place the Battery Pack near flammable materials such as any liquid filled petroleum containers, compressed natural gas/ propane/ welding fuel tanks, natural gas supply lines, oxygen tanks, swimming pool chemicals, home furnaces, or boilers, gas cans/kerosene cans, kerosene/oil powered portable heaters, oil rags, fuel oil tanks, or garbage bins.</li> </ul>
	<ul style="list-style-type: none"> <li>• Do not expose the Battery Pack to water or store or install near water sources.</li> </ul>
	<ul style="list-style-type: none"> <li>• Do not store or install the Battery Pack in direct sunlight or in areas where it could be exposed to lightning.</li> </ul>
	<ul style="list-style-type: none"> <li>• Install the Battery Pack in well-ventilated area with enough ventilation space around the sides and top of the Battery Pack as specified in this Installation Manual to avoid risk of overheating leading to fire.</li> </ul>
	<ul style="list-style-type: none"> <li>• Do not install the Battery Pack in living areas of dwelling units or in sleeping areas.</li> </ul>
	<ul style="list-style-type: none"> <li>• Store and install the Battery Pack on a flat, level surface.</li> </ul>
	<ul style="list-style-type: none"> <li>• Store and install the Battery Pack out of reach of children and animals. Supervise children and animals that are in the vicinity of the product to avoid risk of injury.</li> </ul>

	<ul style="list-style-type: none"> <li>• Store and install the Battery Pack in clean environment, free of dust, dirt and debris.</li> </ul>
	<ul style="list-style-type: none"> <li>• Only qualified personnel should handle, install, uninstall, service and/or repair the Battery Pack.</li> </ul>
	<ul style="list-style-type: none"> <li>• Do not damage the Battery Pack by dropping, deforming, impacting, cutting or penetrating with any sharp object. Doing so may cause a fire or leakage of electrolytes.</li> </ul>
	<ul style="list-style-type: none"> <li>• Do not touch the Battery Pack if liquid spills on it to avoid the risk of electric shock.</li> </ul>
	<ul style="list-style-type: none"> <li>• Do not step on the packaging or the Battery Pack to avoid risk of product damage.</li> </ul>
	<ul style="list-style-type: none"> <li>• Do not rest or place the Battery Pack upside down at any time.</li> </ul>
	<ul style="list-style-type: none"> <li>• Connect the power cable at the terminal block according to the correct polarization. To avoid risk of high current and overcurrent due to short circuits, as well as damage to the battery and inverter, and fire hazards, do not connect the power cable at the terminal block in the opposite direction.</li> </ul>
	<ul style="list-style-type: none"> <li>• Do not charge or discharge damaged Battery Pack.</li> </ul>
	<ul style="list-style-type: none"> <li>• If the Battery Pack is installed in the garage or carport, ensure there is adequate clearance from vehicle for proper ventilation. [min. clearance 3ft(915mm)]</li> </ul>

- Store and install in a cool and dry place. Do not store in greenhouses or storage areas for hay, straw, chaff, animal feed, fertilizers, vegetables, or fruit products.
- The Battery Pack requires adequate clearance for installation, cabling, airflow, safety as detail ed in [3.1.5 system clearance](#).  
(For wall-mounted option, keep lower clearance area free from foreign materials)
- The outer cable connection hole should be sealed to prevent ingress of foreign objects.
- Do not place any foreign objects on the top of the Battery Pack or on the cooling fin.
- The Battery Pack has been certified IP55(Category 2) and can be installed indoors as well as outdoors. If installed outdoors, do not allow the Battery Pack to be exposed to direct sunlight or water sources including rainfall/snowfall, as doing so may cause:
  - Power limitation phenomena in the Battery Pack (with a resulting decrease in energy production by the system).
  - Premature wear of the electrical/electromechanical and mechanical components.
  - Reduction in performance, invalidation of the performance warranty and possible damage of the Battery Pack .
- Only use the GM Energy PowerBank with GM Energy approved inverter.
- If an unapproved inverter is used, there is a risk that the battery's protection functions may not function properly, leading to potential hazards.
- Do not connect any AC conductors or photovoltaic conductors directly to the Battery Pack . The Battery Pack must only be connected to the Inverter.
- The Battery Pack must be installed in accordance all applicable federal, state and local laws, regulations, ordinances and applicable electrical and other codes.
- Follow local ordinance when installing in a garage for vehicle clearance [min. clearance 3ft(914mm)].
- Disposal of the Battery Pack should be carried out by an expert with specialized knowledge and experience in electrical and environmental safety, in accordance with all applicable laws and regulations, at designated waste disposal facilities using safe and appropriate methods.
- The Battery Pack cannot be reused.

### 1.3.1 Response to emergency situations

#### **Fire**

If a fire breaks out at the location where the Battery Pack is installed, evacuate the premises and contact the local emergency authorities immediately.

- If it is safe to do so, the user should disconnect the Battery Pack circuit breaker to shut off the power to charge.
- In the event of a fire near the battery or if the Battery Pack is on fire, do not attempt to extinguish the fire. Immediately evacuate all individuals from the premises.



#### **WARNING**

There is a risk of explosion when the Battery Pack(s) is heated above 302°F(150°C). When a Battery Pack is burning, it will leak poisonous gases. Do not approach a burning Battery Pack. Evacuate the premises and contact the local emergency authorities immediately.

## **Flooding**

Stay out of the water and do not touch anything if any part of the Battery Pack, inverter, or wiring is submerged. Do not use the submerged Battery Pack again. If it is safe to do so, the user should disconnect the Battery Pack circuit breaker to shut off the power to charge. Contact your service engineer for assistance, or contact the emergency authorities if you consider there to be any risk.

## **Exposure to internal materials of the battery cell**

If a user is exposed to the internal materials of the battery cell, the following actions are recommended.

- In case of inhalation: Leave the contaminated area immediately and seek medical attention.
- In case of contact with eyes: Rinse eyes with running water for 15 minutes and seek medical attention.
- In case of contact with skin: Wash the contacted area thoroughly with soap and seek medical attention.
- In case of ingestion: Seek medical attention immediately.

## **1.4 Label**

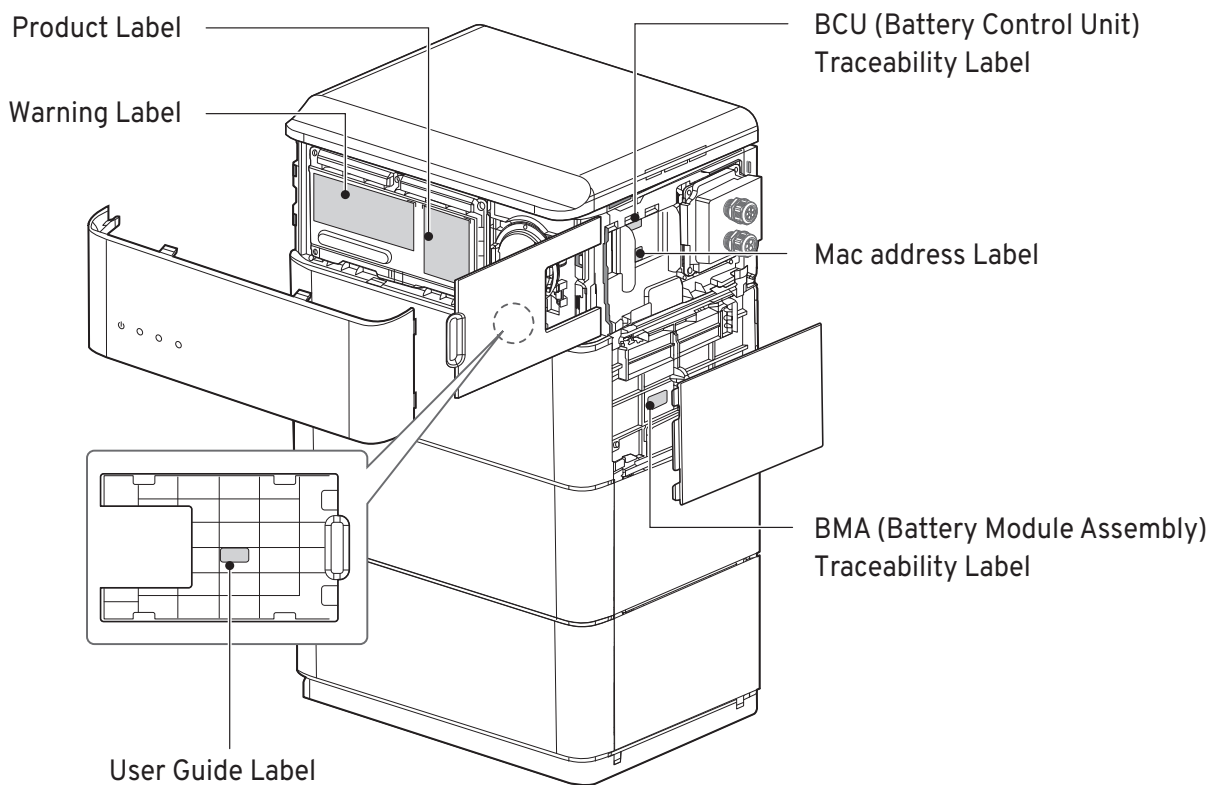

## 1.4.1 Warning label

# DANGER / HIGH VOLTAGE INSIDE

- Do not disassemble or repair to avoid injuries, electric shock or burns. Service by authorized personnel only.
- Do not charge or discharge arbitrarily. It may lead to fault, electric shock or burns.
- Do not damage the unit in such ways as drop, deform, impact, cut or spear with a sharp object. It may cause electrolyte leakage.
- Measure DC voltages before working in wiring box.
- **WARNING:** Battery system is a bidirectional source of voltage. Battery circuit breaker, and inverter must both be off, before working in the wiring box.
- Do not attempt to break open the unit. The units are only serviceable by certified personnel.

Protective Class 1

- Do not place near open flame or incinerate. Keep out of reach of children or animals.
- Do not install this product in the place exposed to the direct sunlight.
- Sometimes even if the DC Disconnect is OFF, there may be voltage on the lines to the Inverter. So please ensure the DC Disconnect on the Inverter is also OFF during service/maintenance.
- Single person lift could cause injury. Use assistance when moving or lifting.
- Electric shock hazard if a ground fault is indicated, normally grounded conductors may be Ungrounded and energized.

- **WARNUNG:** Das Batteriesystem ist eine bidirektionale Spannungsquelle. Batterie-Freischalter und Wechselrichter müssen ausgeschaltet sein bevor Sie an beiden Geräten arbeiten wollen.
- Versuchen Sie nicht die Batterie aufzubrechen. Die Geräte sind nur durch zertifiziertes Personal bedienbar.
- Platzieren Sie die Batterie nicht in der Nähe von offenem Feuer oder Zündquellen.
- Halten Sie Kinder und Tiere fern.
- Installieren Sie die Batterie nicht in Umgebungen wo sie direktem Sonnenlicht ausgesetzt ist.

- Es kann vorkommen, dass selbst im ausgeschalteten Zustand des Speichers eine Spannung zwischen Batterie und Wechselrichter messbar ist.
- Also stellen Sie immer sicher, dass der DC-Trenner des Wechselrichters ist auch ausgeschaltet während Wartungen oder Service-Arbeiten durchgeführt werden.
- Einzelne Personen können sich beim Anheben des Speichers verletzen. Holen Sie sich Hilfe, wenn sie den Speicher versetzen oder anheben müssen.
- Es herrscht Stromschlaggefahr, wenn es zu einem Erdschluss kommen sollte. Es kann vorkommen, dass geerdete Leiter doch nicht geerdet wurden und unter Strom stehen.

- **ATTENTION :** Le system de la batterie est une source de tension bidirectionnelle. Le disjoncteur du circuit de batterie et l'onduleur doivent être hors tension avant câbleage.
- Ne pas placer près d'une flamme ou incinérer le produit.
- Tenir hors de portée des enfants ou d'animaux.
- Ne pas installer le produit dans un endroit directement exposé au soleil.
- Parfois, même si le courant continu est coupé, il peut y avoir du courant dans les lignes de l'onduleur. Assurez vous donc que l'onduleur est également hors tension durant les interventions de maintenance.
- Porter l'appareil seul personne entraine un risque de blessure. Merci de demander une assistance pour porter ou déplacer l'appareil.
- Si un défaut de la terre est indiqué alors il y a risque de choc électrique. Dans ce cas il se peut que la mise à la terre ne fonctionne pas.

### 1.4.2 Product label

※ Please use a permanent marker to mark the box that matches the product name on the label.



Model name : **EU0407N00B**      Rated capacity : **71.0 Ah**  
 Modellname : **EU0407N00B**      Nennkapazität : **71.0 Ah**  
 Nom du modèle : **EU0407N00B**      Capacité nominale : **71.0 Ah**

Battery type : **Rechargeable Li-ion**      IP rating : **IP55 (Category 2)**  
 Batterietyp : **Rechargeable Li-ion**      Schutzklasse : **IP55 (Category 2)**  
 Type de batterie : **Rechargeable Li-ion**      Evaluation : **IP55 (Category 2)**

Nominal voltage (Charge/Discharge) : **420V / 410V**  
 Nominale Spannung (Ladung/Entladen) : **420V / 410V**  
 Tension nominale (Charge/décharge) : **420V / 410V**

Product name Produktname Nom du produit	Total weight Gesamtgewicht Poids total	Nominal energy Nominale Energie Energie nominale	Short Circuit Current(Duration) Kurzschlussstrom(Dauer) Courant de court-circuit(Durée)	Battery Designation Batteriebezeichnung Désignation de la batterie
<input type="checkbox"/> EU0407N00B_3S (PowerBank e1.10)	121.5 kg	10.6 kWh	1.35 kA (1.31 ms)	INP17/102/354/ [1P42S]M-20+50/90
<input type="checkbox"/> EU0407N00B_5S (PowerBank e1.17)	192.1 kg	17.7 kWh	1.35 kA (1.31 ms)	INP17/102/354/ [1P70S]M-20+50/90

Manufactured by LG Energy Solution  
 Designed in / Manufactured in Korea  
 Hergestellt in Korea  
 Fabriqué en Corée



ANSI/UL1973

c      us

\* See User's Guide for more details  
 \* Siehe Benutzerhandbuch für weitere Details  
 \* Voir le guide d'utilisateur pour plus de détails.



### 1.4.3 Traceability label

※ This image is an example.

BCU Label



BMA Label



### 1.4.4 Mac address label

※ This image is an example.



### 1.4.5 User guide and warranty label

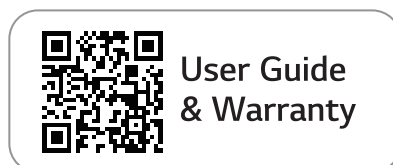



# 2 Product Introduction

## 2.1 Technical data

### 2.1.1 Specification

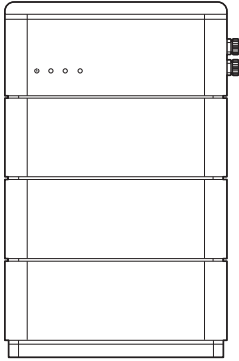
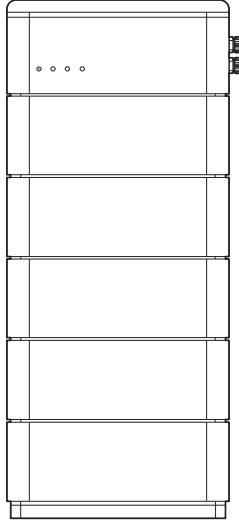
Mechanical Characteristics		
	e1.10	e1.17
Image		
Width	535.2mm (21.1")	
Height	853.4mm (33.6")	1245.0mm (49.0")
Depth	351mm (13.8")	
Weight	121.5 kg (267.9lb)	192.1 kg (423.5lb)

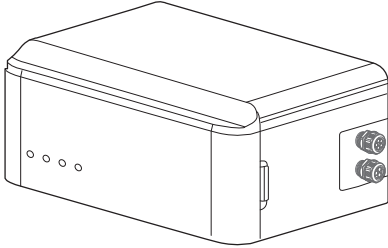
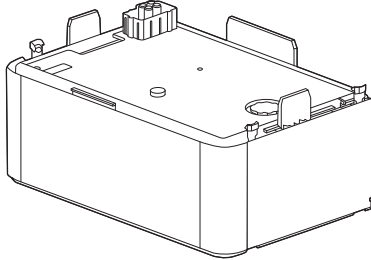
Mechanical Characteristics (BCU, BMA)		
Name	BCU	BMA
Image		
Weight	14.1 kg (31.1lb)	35.3 kg (77.8lb)

<b>Electrical Characteristics</b>			
		<b>e1.10</b>	<b>e1.17</b>
Usable Energy <sup>1)</sup> 77°F(25°C)		10.6kWh	17.7kWh
Voltage Range	Charge	420~450Vdc	
	Discharge	350~410Vdc	
Max. Current		20A	
Max. Charge/Discharge Power		5 kW	7 kW
Peak Power <sup>2)</sup>		7 kW	11 kW
Communication Interface		RS485	
DC Protection		Circuit Breaker, Fuse, DCDC converter	
Connection Method		Spring Type Connector	
User interface		LEDs for Normal and Fault operation	
Protection Features		Over Voltage / Over Current / Short Circuit	
Scalability (Total Energy, Max. Charge/Discharge Power)		Max. 2 in parallel	

<b>Operating Conditions</b>		
Installation Location		Indoor / Outdoor
Installation Type		Stand / Wall Mount
Operating Temperature	Charge	14 ~ 122°F (-10 ~ 50°C)
	Discharge	-4 ~ 122°F (-20 ~ 50°C)
Operating Temperature (Recommended)		59 ~ 86°F (15 ~ 30°C)
Storage Temperature (At shipping state)		-22 to 140°F (-30 to 60°C), acceptable for 7 days in total -4 to 113°F (-20 to 45°C), acceptable for the first 6 months -4 to 86°F (-20 to 30°C), acceptable for 7 to 12 months
Humidity		5 ~ 95%
Altitude		Max. 6,562ft (2,000m)
Cooling Strategy		Natural Convection

Certification & Reliability		
Safety	Cell	UL1973 Annex E, IEC62619
	Battery Pack	UL1973, UL9540A
EMC		FCC
Transportation		UN38.3 (UNDOT)
Hazardous Materials Classification		Class 9
Ingress Rating		IP55 (Category 2)
Working Voltage (System Voltage)		600V
Overvoltage Category (North America)		OVC 3

※ Test Conditions - Temperature 77°F (25°C), at the beginning of life

※ Usable Energy is measured under specific condition from GM Energy. (0.3CCCV/0.3CC)

※ Product specification may change without notice.

1) DOD 100%

2) Peak Current excludes repeated short duration. (less than 10 sec. of current pattern)

## 2.2 Short Circuit Current & Duration

Short Circuit Current	1.35kA
Duration	1.31ms

## 2.3 Arc Flash Protection Calculation

In order to protect personnel from the possibility of getting injured by an arc flash hazard, Arc flash calculation of the battery system is estimated with the Incident Energy Calculations refer to Annex D of NFPA 70E.

	e1.10	e1.17
Battery System Voltage	172.2V	287.0V
Battery System Internal Resistance	0.08Ω	0.13Ω
Bolted Fault Current	1.35kA	1.35kA
Arcing Current	1.35kA	1.35kA
Clearing Time	686us	560us
Arc Flash Incident Energy	0.00091Cal/cm <sup>2</sup>	0.00121Cal/cm <sup>2</sup>
Working Distance	450mm (18inch)	450mm (18inch)

Battery system installers must wear PPE (Personal Protective Equipment) according to relevant local standards, for example NFPA 70E Article 130.

\* NFPA (National Fire Protection Association)



## WARNING

- When installing the Battery Pack, qualified personnel must wear arc-rated clothing at all times and in all places when handling or near the Battery Pack to protect him/her from any possible exposure to an electric arc flash.  
The arc-rated clothing worn by the qualified personnel must allow for the qualified personnel's movement and visibility and must cover all ignitable clothing.
- Qualified personnel must wear a non-conductive safety helmet at all times and in all places when handling or near the Battery Pack to protect him/her from any danger of head injury from electric shock or electrical burns due to the contact with energized electrical conductors or circuit parts resulting from electrical explosion.
- Qualified personnel must wear non-conductive protective equipment for the eyes, face, neck, and chin at all times and in all places when handling or near the Battery Pack to protect him/her from danger of injury from exposure to electric arcs or flashes resulting from an electrical explosion.
- Qualified personnel must wear hearing protection within the arc flash boundary.
- Qualified personnel must wear heavy-duty leather gloves or arc-rated gloves, satisfying local safety standards, for arc flash protection. If wearing rubber gloves for shock protection, he/she must wear additional leather protection over the gloves.
- Qualified personnel must wear heavy-duty leather footwear or dielectric footwear to provide arc flash protection.
- Qualified personnel must inspect arc-rated apparel before every use. Work clothing or arc flash suits that are contaminated or damaged to the extent that the protective qualities of the work clothing or arc flash suit is impaired, must not be used. Protective items that become contaminated with grease, oil, flammable liquids or combustible materials must not be used.
- The garment manufacturer's instructions for care and maintenance of arc-rated apparel must be followed.
- Arc-rated apparel shall be stored in a manner that prevents physical damage, damage from moisture, dust, or other deteriorating agents, or contamination from flammable or combustible materials.

## 2.4 Features

- Compact energy storage unit for domestic photovoltaic system compatibility
- Residential DC Battery Pack system: Daily cycle and emergency back-up capability
- Protection devices included as follows:
  - Inverter Power Interface for protection against overvoltage, overcurrent, external short-circuit, reverse polarity, inrush current and over temperature
  - Battery Power interface for protection against internal short-circuit, overvoltage, overcurrent, overtemperature and undervoltage
- Flexible installation: Indoors or Outdoors
- If installed outdoors, the Battery Pack must be protected from direct sunlight and rain or other sources of moisture, and must satisfy all the safety requirements and general requirements specified in this installation manual.

## 2.5 Maintenance

The Battery Pack does not require maintenance during normal operation if properly installed by qualified personnel according to this Installation Manual. In the event of a fault arising, or if you believe that maintenance may be required, contact GM Energy Support Center or your distributor.

# 3 Installation & Uninstallation

## 3.1 Installation Requirements

### 3.1.1 Package Contents

#### 3.1.1.1 Battery Control Unit (BCU) Package Contents

These items are included in the Battery Pack's BCU package.



### CAUTION

For attaching the Battery Pack to a wall, fasteners are not included.

Please purchase appropriate fasteners separately and refer to Sections [3.1.7.1 Standing Type](#), [3.1.7.2 Wall Mounting Bracket Type](#) and [3.1.7.3 Base Bracket Type](#) of this Installation Manual for more information about what fasteners are appropriate for each installation type.

### 3.1.1.2 Battery Module Assembly (BMA) Package Contents

These items are included in the battery module package.

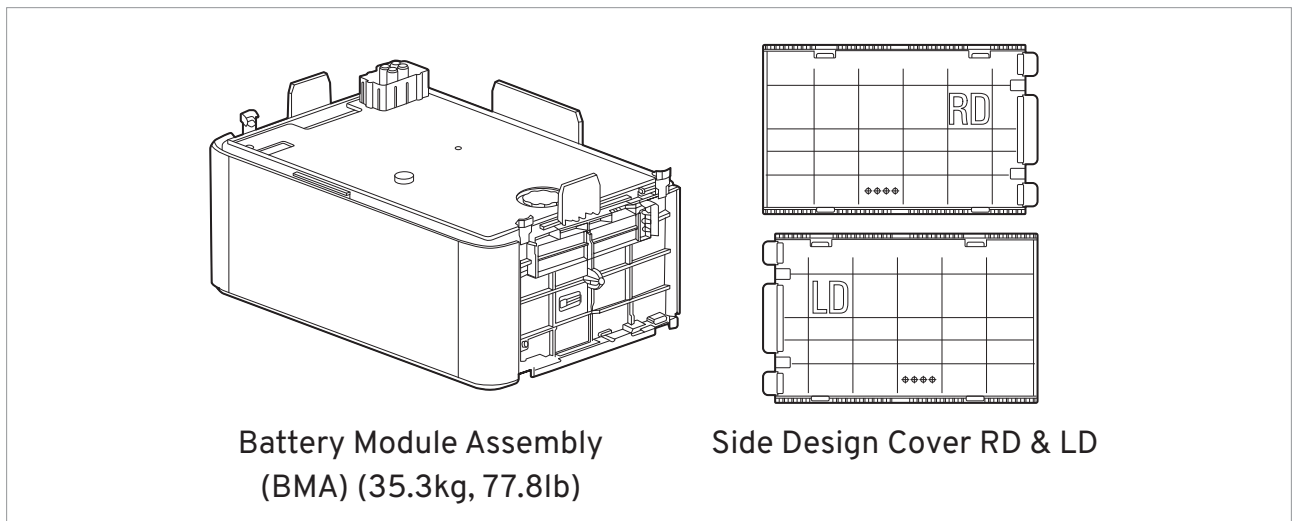

#### (1) Number of BMAs (Battery Module Assembly)

Series Name	Product Name	Number of BMAs
GM Energy PowerBank e1.10	EU0407N00B_3S	3 BMAs
GM Energy PowerBank e1.17	EU0407N00B_5S	5 BMAs

### 3.1.1.3 Accessories

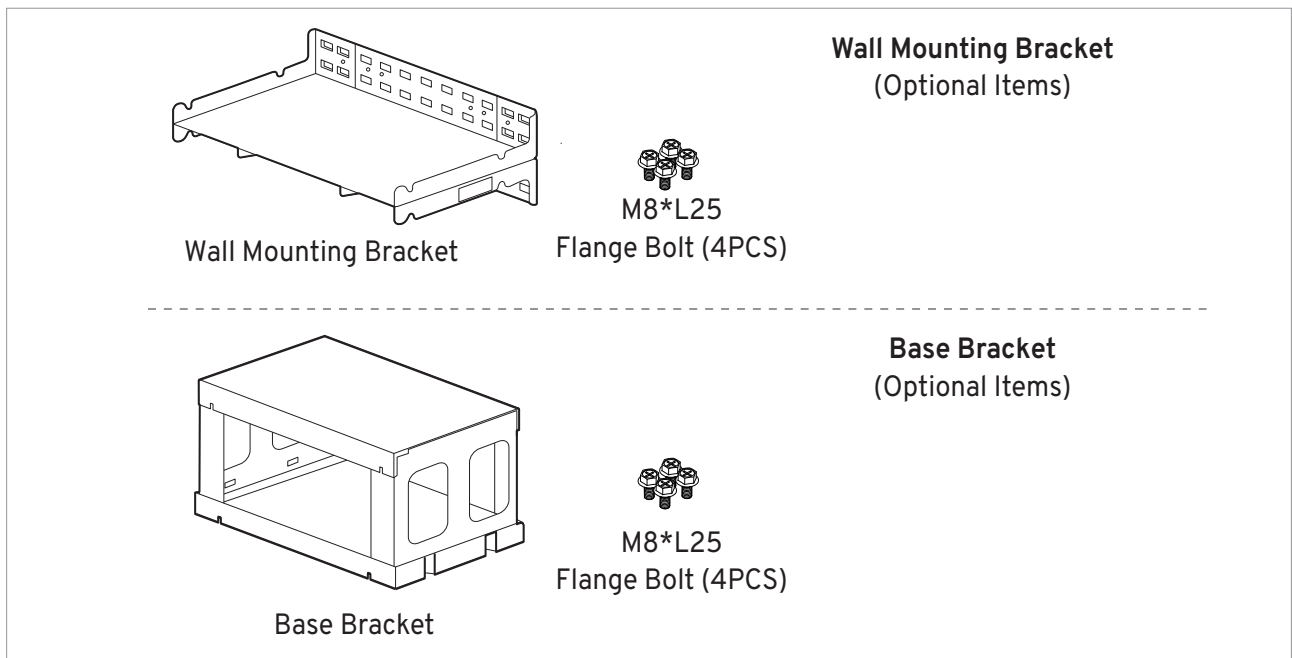

### 3.1.2 Basic Lifting Guide

Refer to below guide for lifting and carrying the BCU and BMA during installation to avoid accidental product damage (Recommended number of installers: 1 to 2 installers)

#### Handling Position

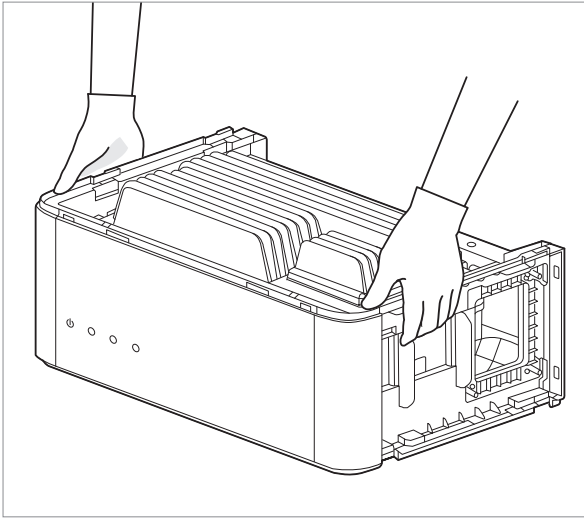

BCU (Battery Control Unit)

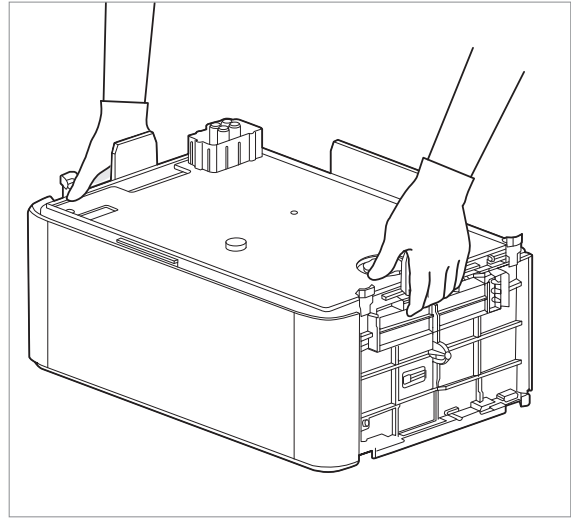

BMA (Battery Module Assembly)

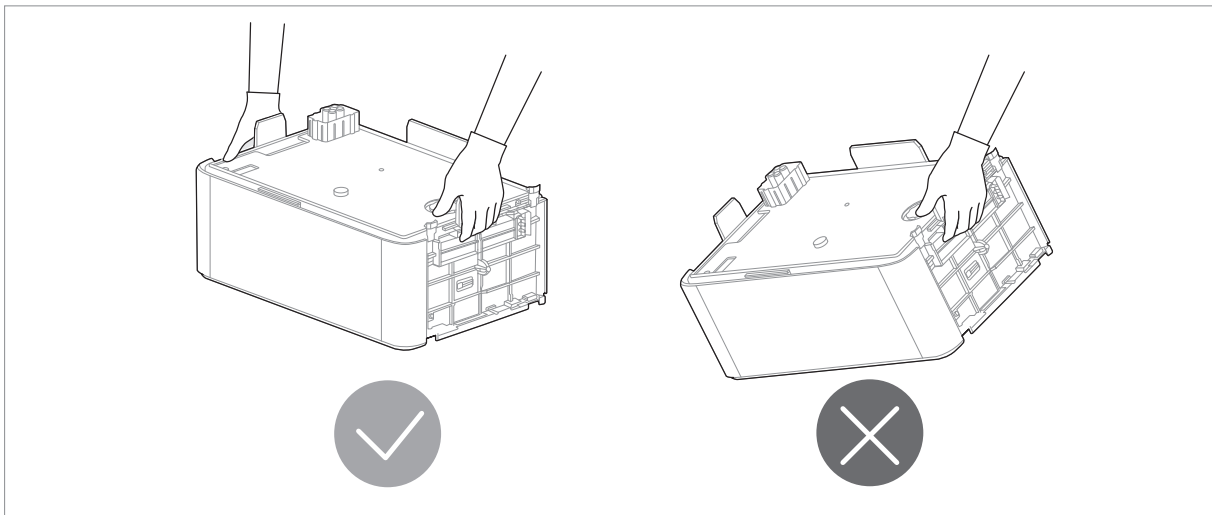

#### WARNING

- Do not drop the Battery Pack during handling.
- Damaged batteries are dangerous and must be handled with extreme caution. They are not fit for use and may pose a danger to people or property. If the Battery Pack seems to be damaged, do not proceed with installation and contact GM Energy Support Center or your distributor.



### 3.1.3 Unboxing the Battery Pack

#### 3.1.3.1 Battery Control Unit (BCU) unboxing

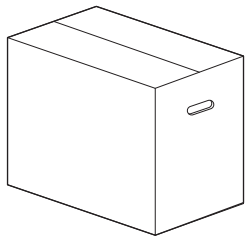

1. Prepare the box.

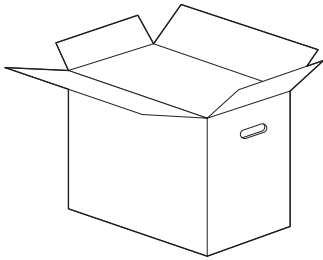

2. Remove the top tape and open the box.

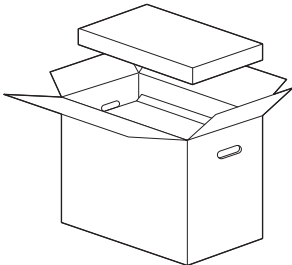

3. Take out the accessories box.

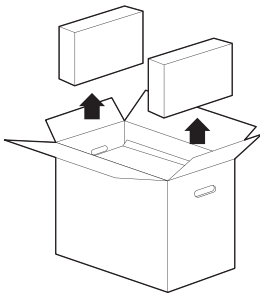

4. Take out the honeycomb fillers.

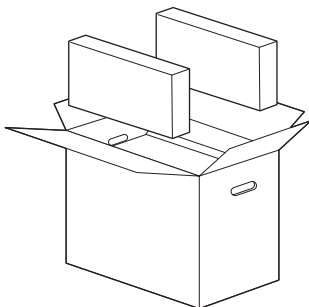

5. Take out the Bottom Plate box and the Top Cover box.

 **CAUTION**

Place the Bottom Plate on the floor before stacking the BMA.

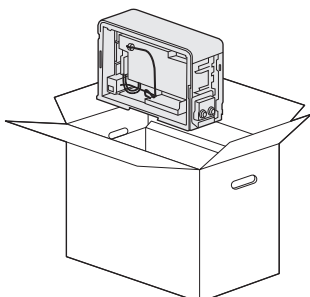

6. Open the plastic wrap and take out the BCU.

### 3.1.3.2 Battery Module Assembly (BMA) unboxing

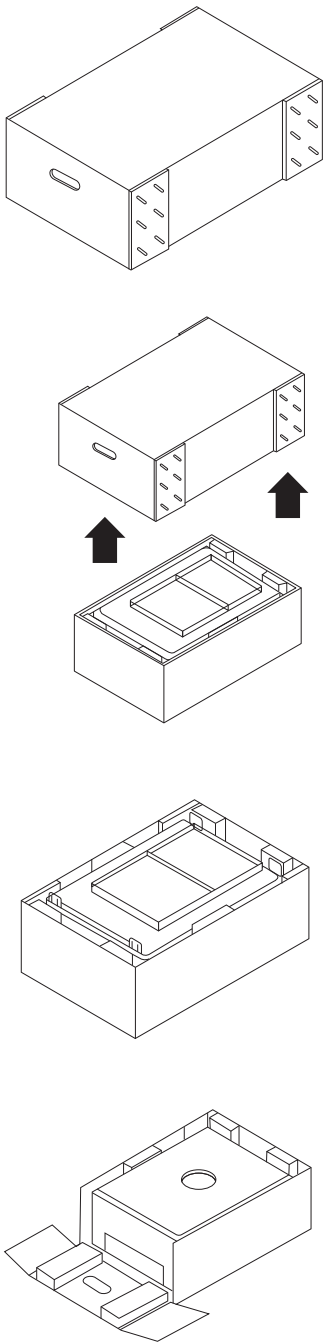

1. Prepare the box.

2. Open the box cover.

3. Open the plastic wrap and take out the Side Design Cover.

4. Open the side wall of the box and take out the BMA.

**CAUTION**  
One side wall is not fixed to the box, so be careful when moving.

#### **WARNING**

Damaged batteries are dangerous and must be handled with extreme caution. They are not fit for use and may pose a danger to people or property. If the Battery Pack seems to be damaged, do not proceed with installation and contact GM Energy Support Center or your distributor.

### 3.1.4 Installation locations

#### Requirements:

- Ensure the installation location is free of flammable or explosive materials.
- The installation location's ambient temperature should be within the range of -4°F to 122°F (-20°C to 50°C).
- The Battery Pack must be installed on a flat levelled surface that can support its weight and away from potential damages like flooding (examples of unsuitable surfaces are grass, rock, artificial turf, dirt, gravel, etc.).
- The Battery Pack must be kept away from direct sunlight and rain or other sources of moisture. This applies to both indoor and outdoor installations. Even if installed indoors such as basement or garage, direct sunlight and rain or other sources of moisture may still penetrate, so it is essential to protect the Battery Pack from direct sunlight and rain or other sources of moisture.
- If the Battery Pack is installed indoors, there should be a free space of at least 8.9383m<sup>3</sup> inside the room for UL9540A compliance and proper ventilation.

#### Recommendations:

- The building where the Battery Pack is installed should be designed to withstand earthquakes.
- The Battery Pack should be installed in an area with no water infiltration and that is well ventilated. The Battery Pack should be installed in well-ventilated area with enough ventilation space around the sides and top of the Battery Pack as specified in this Installation Manual to avoid risk of overheating leading to fire.
- The Battery Pack should be installed out of reach of children and animals. Supervise children and animals within the vicinity of the Battery Pack.

#### CAUTION

If the ambient temperature is outside operating range, the Battery Pack will stop operating to protect itself. The optimal operating temperature range for the Battery Pack is from 59°F to 86°F (15°C to 30°C).

Frequent exposure to harsh temperatures may deteriorate the performance and life of the Battery Pack.

### 3.1.5 System clearance

Recommended clearances for the left, right, top and rear of the product are shown in the figure for the proper ventilation.

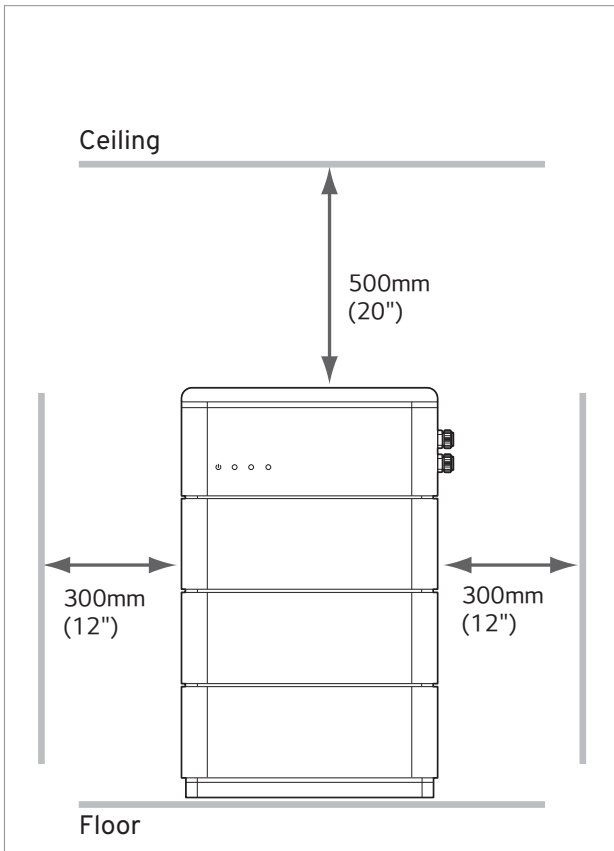

Standing Type

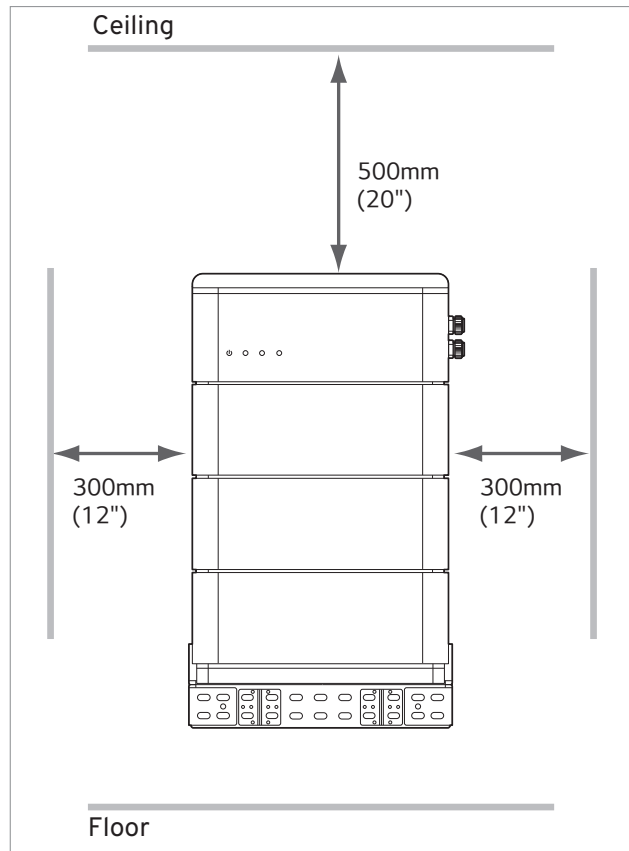

Wall Mounting Type

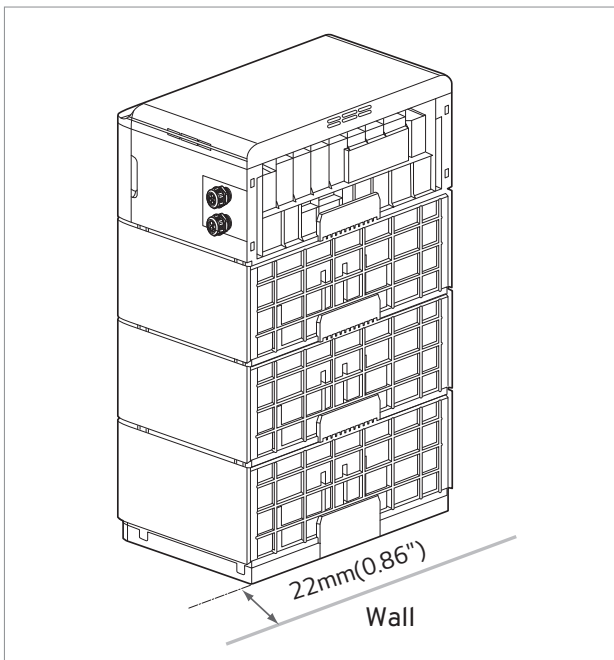

Standing / Wall Mounting Type

#### NOTICE

The side clearance is recommended to be 300mm (12") and minimum 250mm (10") for UL9540A compliance.

#### NOTICE

If a battery is installed indoors, there should be a free space of at least 8.9383m<sup>3</sup> inside the room for UL9540A compliance.

### 3.1.6 Required Tools

The following tools are required to install the Battery Pack :

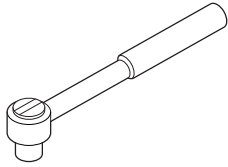

M6, M8 Torque wrench

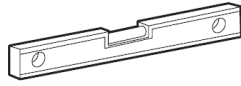

Inclinometer or spirit level

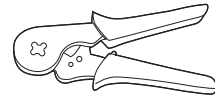

Ferrule Crimping Tool



Drill  
(Min. Diameter 10mm, 0.4")



Pencil or Marker

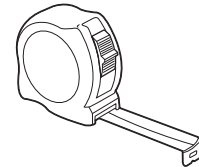

Tape measure

- Safety gear for personal protection

Only handle the Battery Pack when wearing the following safety gear:



Insulated gloves



Safety goggles



Safety shoes

### 3.1.7 Installation Instructions for the Battery Pack

#### 3.1.7.1 Standing Type

These are the installation instructions for Standing Type installation only. For other methods of installation, please see Sections [3.1.7.2 Wall Mounting Bracket Type](#) or [3.1.7.3 Base Bracket Type](#) of this Installation Manual.

#### CAUTION

Make sure that the inverter AC and DC are turned off and disconnected before connecting the power cable to the Battery Pack.

For a Standing Type Battery Pack installation, perform the following in order:

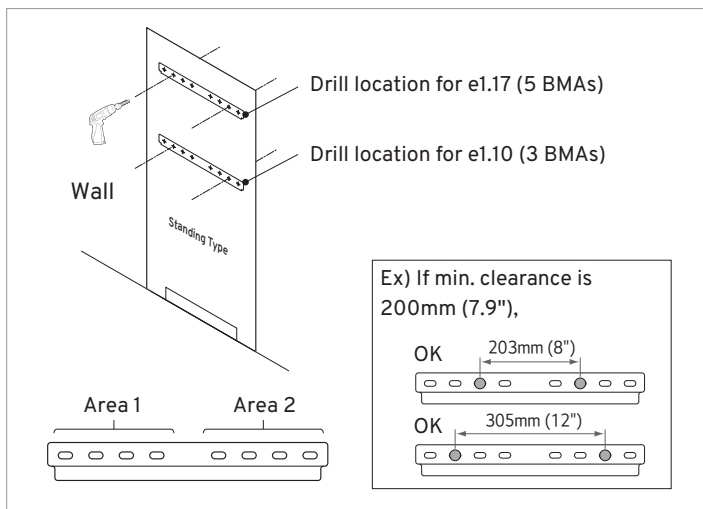

#### (1) Drill template

- a) Place the Standing Type drill template against the wall, check if it is level and drill holes at the positions marked on the Standing Type drill template.

#### NOTICE

- Recommended fastener count: 1 (Area1), 1 (Area2)
- Recommended fastener diameter: Min. 10mm (0.4")
- Recommended fastener length: Min. 40mm (1.6")
- The spacing between fasteners should comply with the regional building codes.

#### CAUTION

The fasteners for the Standing bracket 1 are not included, so please purchase appropriate fasteners separately.  
(Standing Bracket part 1 hole : 15mm)

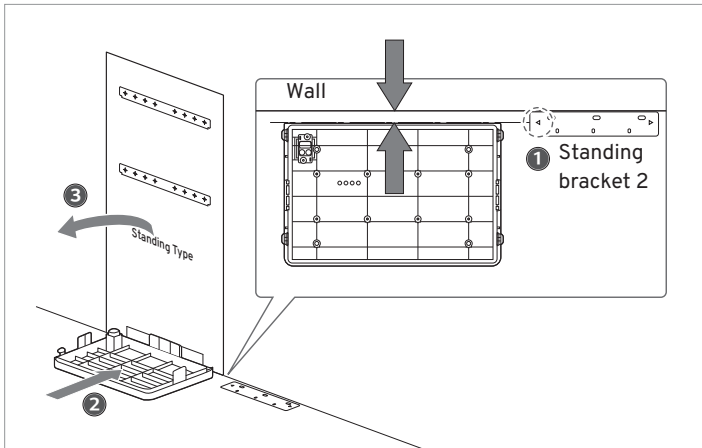

- b) Place the Standing bracket 2 just beside the wall and position the Bottom plate at the location of the arrow. ①
- c) Fit the Bottom plate to the Standing Type Drill template. ②
- d) Remove the Standing Type Drill template and the Standing bracket 2. ③

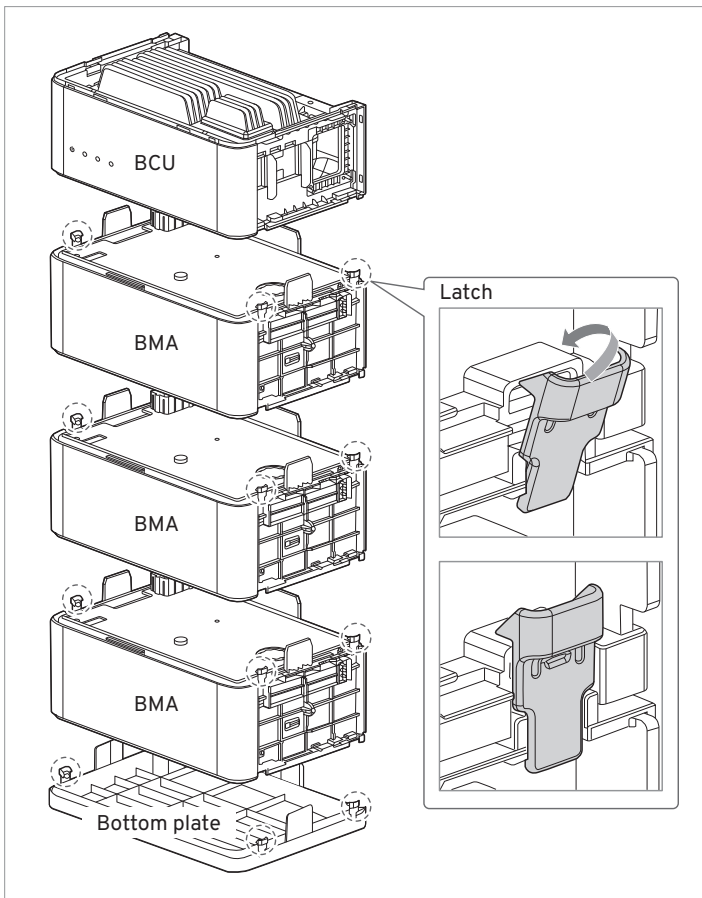

## (2) Stack

- Stacking order : Bottom plate ⇄ BMA ⇄ BCU

### NOTICE

PowerBank e1.10 has 3 BMAs and PowerBank e1.17 has 5 BMAs.

### CAUTION

- Make sure to secure each latch on the modules when stacking.
- Make sure to align the back and side stacking guides.
- Check for a "click" sound when closing the latch to ensure the latch is fully closed.

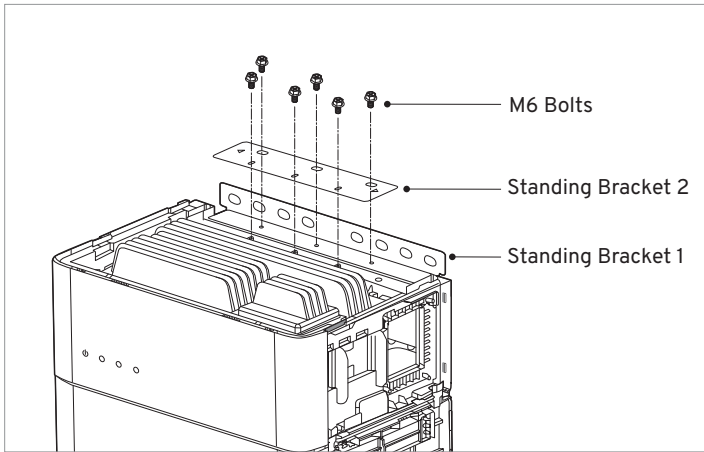

### (3) Standing Bracket

- After fixing the Standing bracket 1 on the wall, fix the Standing bracket 2.

#### NOTICE

Tighten the six(6) M6 SEMS bolts with a torque of 5N·m (3.7lbf·ft).

#### CAUTION

The fasteners for the Standing bracket 1 are not included, so please purchase appropriate fasteners separately.  
(Standing Bracket part 1 hole : 15mm)

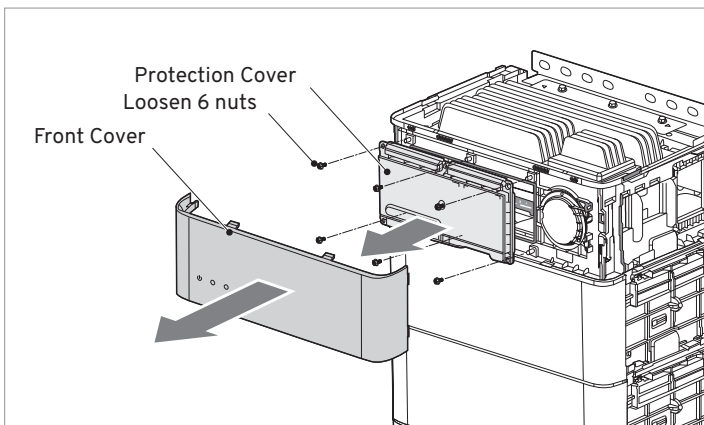

### (4) Cable connection

- Remove the front cover.
- Remove the protection cover.

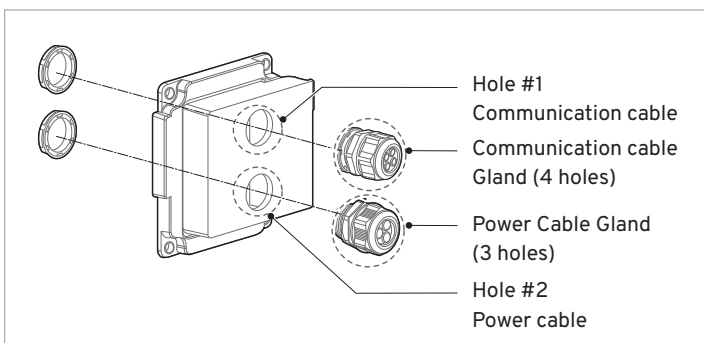

- Assemble cable glands on side sealing cover.

#### CAUTION

Assembling cable glands is not essential.

Therefore, assemble the adapter or cable gland to the side sealing cover holes according to regional regulations.

To ensure waterproof/dustproof protection, holes must be sealed by other means if the gland is not being used.



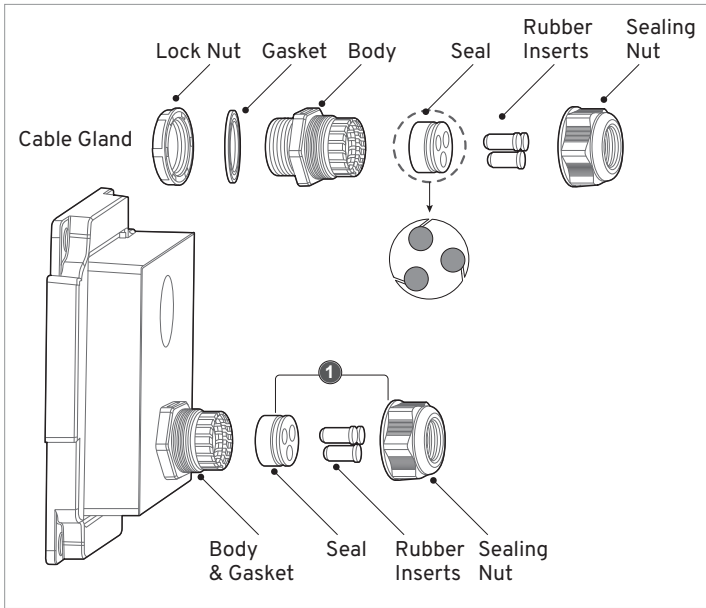

d) Remove sealing nut and rubber inserts and insert the cables into the seal slit.

①

(Please remove only the required quantity of rubber inserts)

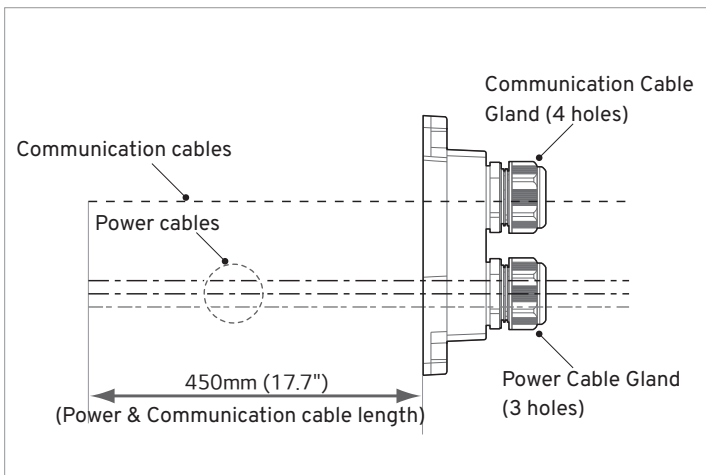

e) After inserting the cables, tighten the sealing nut of the cable gland.

#### NOTICE

- Communication cable  
Max. cable length: 35ft(10m),  
Cable type: 0.326~1.646mm<sup>2</sup> (18~22AWG/  
Cable Outer Diameter of Jacket  $\phi$ 5~6mm  
( $\phi$ 2~2.4"))

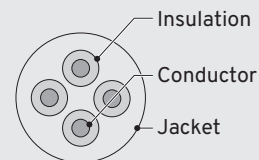

※ Apply the core cable as shown in the picture above when using a communication cable in a communication cable gland.

- Power cable  
Max. cable length: 35ft(10m),  
Cable type: 8mm<sup>2</sup> (8~10AWG/Cable Outer  
Diameter  $\phi$ 6~7mm ( $\phi$ 2.4~2.8"))

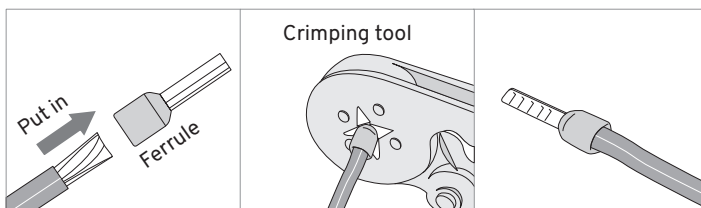

#### NOTICE

The ferrules used varies between the single or parallel modes (see [3.1.1 package contents](#)). For instance, the single type ferrule will be used for the single module connection, and the twin type ferrule will be used, when 2 different modules are connected parallel to each other.

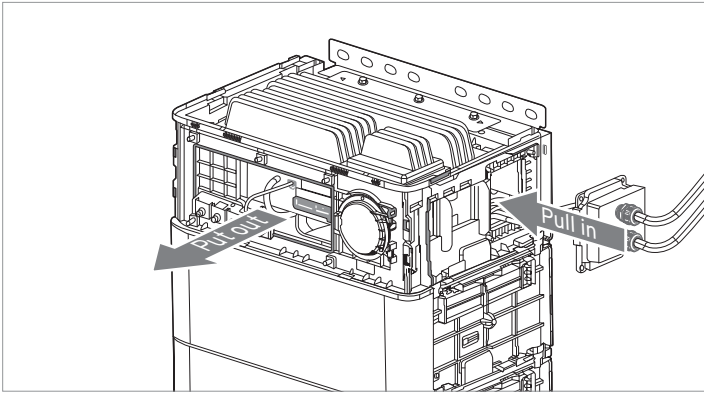

f) Cable in & out along the direction of the arrow.

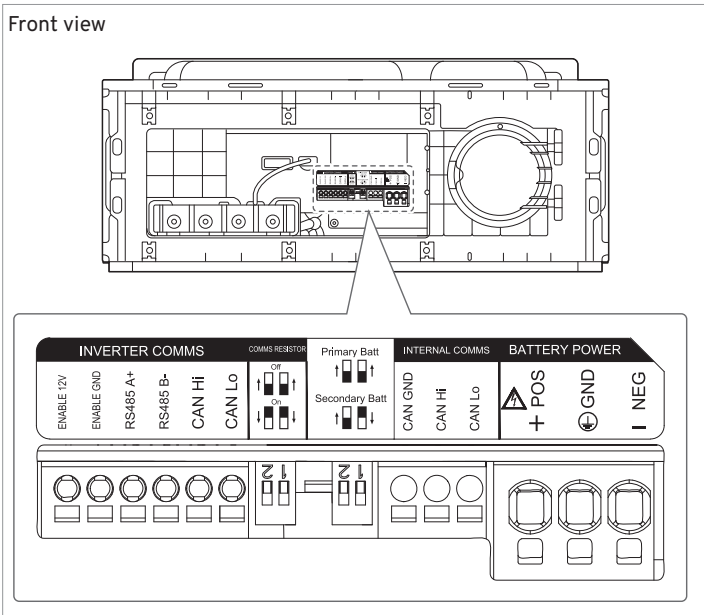

g) Connect the enable cable, the communication cable and the power cable to the terminal connector located on BCU.

**CAUTION**

- Refer to Section 3.2 Cable connections for cabling.

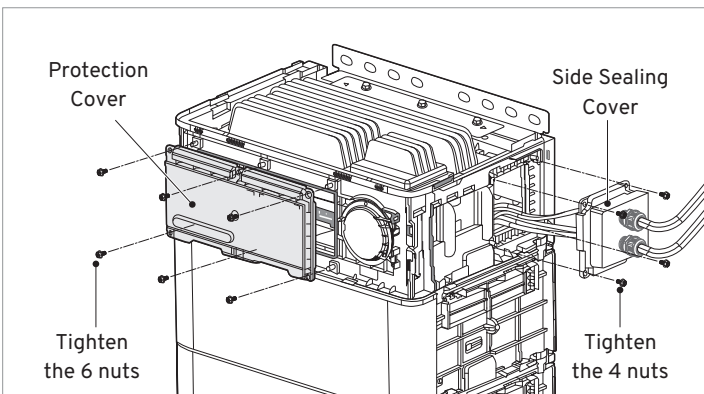

h) Reassemble the protection cover and side sealing cover.

**NOTICE**

Tighten the M6 Nuts with a torque of 7N·m (5.2lbf·ft).

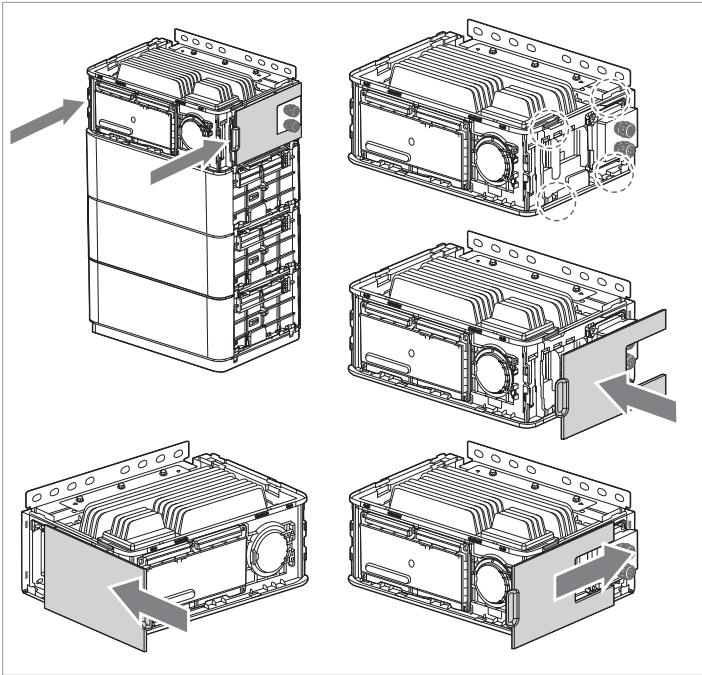

**(5) Cover assembly**

a) BCU Side design cover : Find the connecting tab and slide the cover along the direction of the arrow.

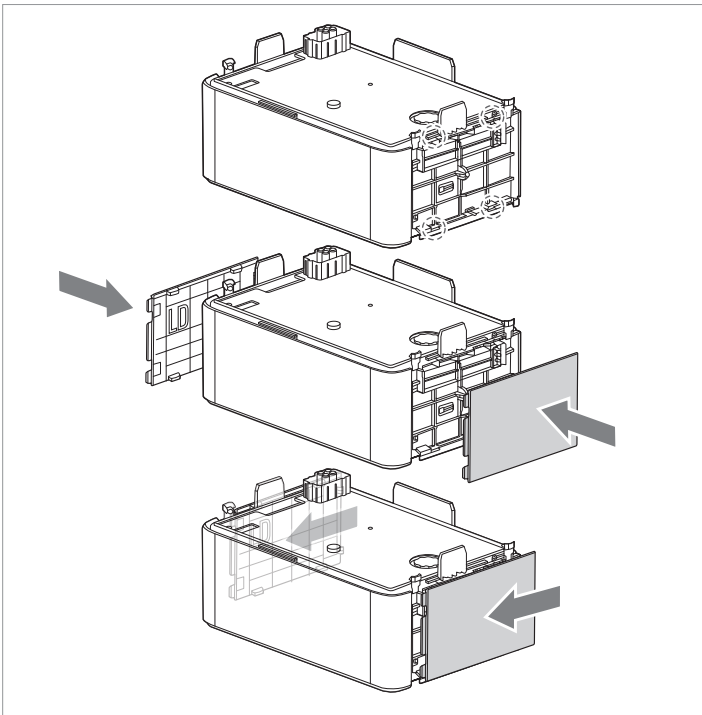

b) BMA Side design cover : Find the connecting tab and slide the cover along the direction of the arrow.

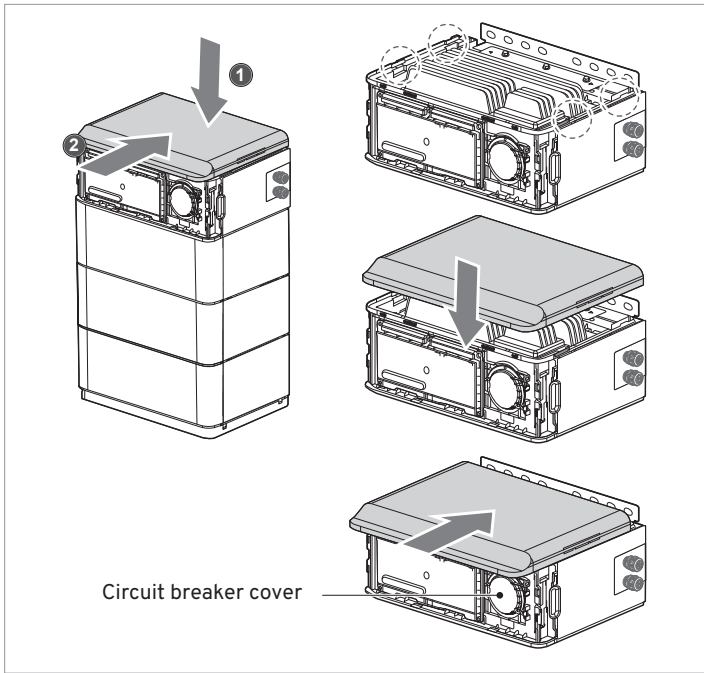

c) BCU top cover : Find the connecting tab and slide the cover along the direction of the arrow.

**NOTICE**

Turn on the circuit breaker for power initialization.

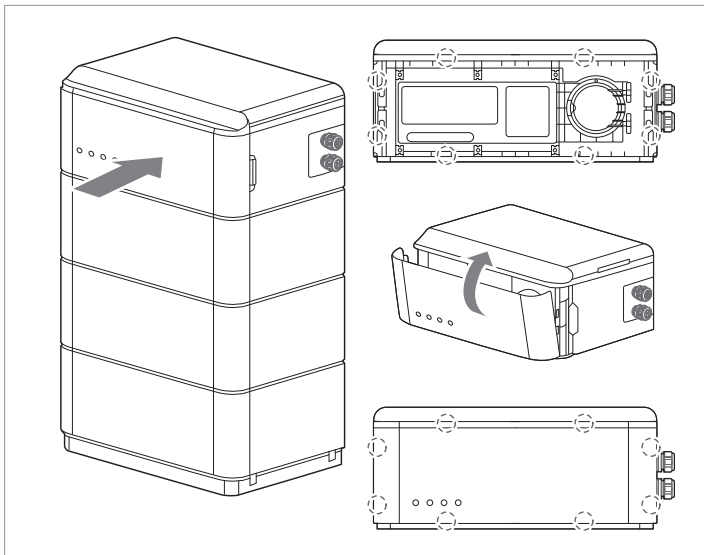

d) Front cover : Find the hook points and press the points to assemble it.

**CAUTION**

Please double-check that the covers are properly assembled and not coming apart.

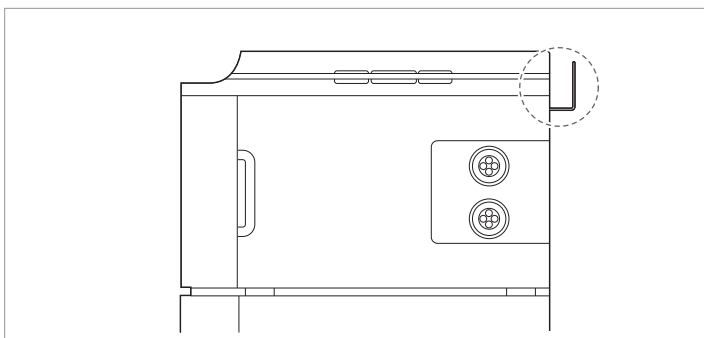

**CAUTION**

Make sure that the Standing brackets 1&2 are engaged.

### 3.1.7.2 Wall Mounting Bracket Type

#### CAUTION

Make sure that the inverter AC and DC are turned off and disconnected before connecting the power cable to the Battery Pack.

Install Battery Pack in the following order.

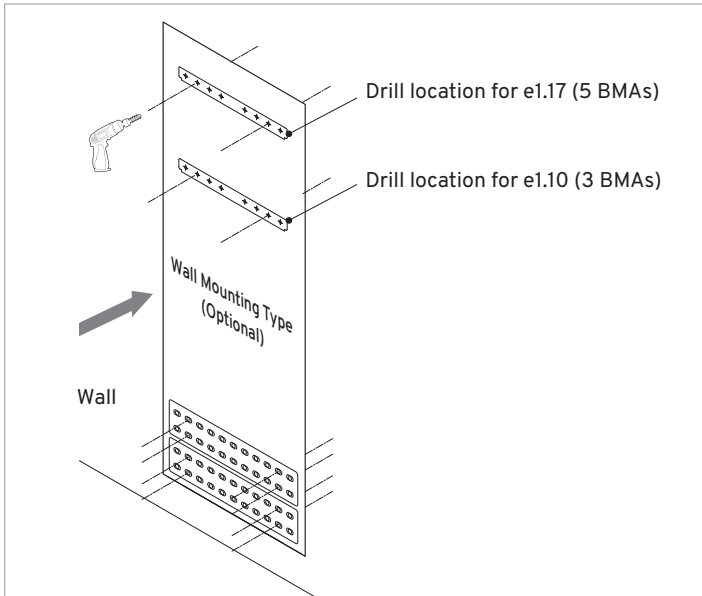

a) Place the Wall Mounting Type drill template, check if it is level and drill holes in the positions marked on the Wall Mounting Type Drill template.

#### NOTICE

The number of fasteners should comply with the regional building code. GM Energy recommends the use of at least eight(8) fasteners for the Wall mounting bracket and two(2) fasteners for the Standing bracket 1.

#### NOTICE

- Recommended fastener diameter: Min. 10mm (0.4")
- Recommended fastener length: Min. 40mm (1.6")
- The spacing between fasteners should comply with the regional building code.

#### CAUTION

The fasteners for the Standing bracket 1 and the Wall mounting bracket are not included, so please purchase appropriate fasteners separately.

(Wall Mounting Bracket hole : 12mm,  
Standing Bracket part 1 hole : 15mm)

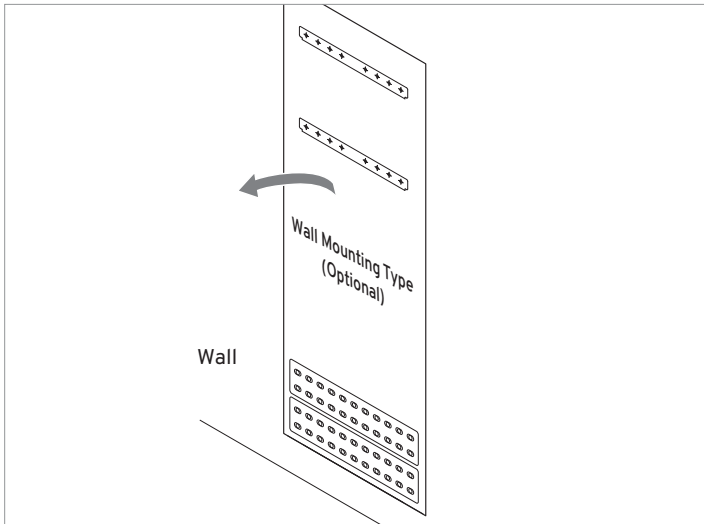

b) Remove the Wall Mounting Type Drill template from the wall.

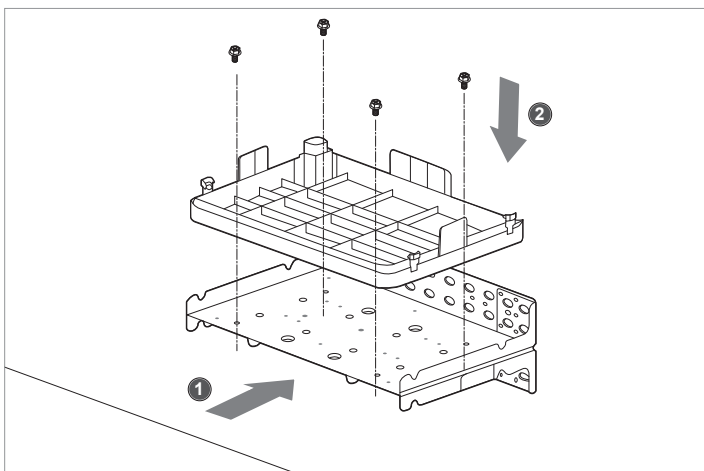

c) Fix the Wall mounting bracket on the wall. ①

d) Place and fix the Bottom plate on the Wall mounting bracket. ②

**CAUTION**

Please fix the Bottom plate using M8\*L25 flange bolts with the Wall mounting bracket.

**NOTICE**

Tighten the four(4) M8 flange bolts with a torque of 5N·m(3.7lbf·ft).

**CAUTION**

The fasteners for the Wall mounting bracket are not included, so please purchase appropriate fasteners separately.  
(Wall Mounting Bracket hole : 12mm)

e) Please follow the installation instructions set out in Sections 3.1.7.1 (2) - (5) of this Installation Manual.

### 3.1.7.3 Base Bracket Type

#### CAUTION

Make sure that the inverter AC and DC are turned off and disconnected before connecting the power cable to the Battery Pack.

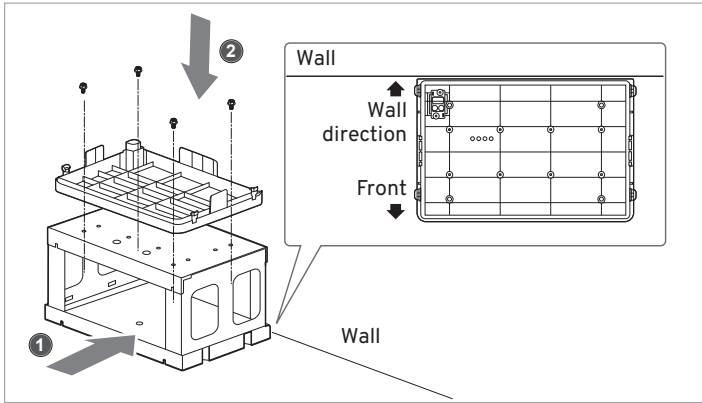

Install the Battery Pack in the following order.

- a) Place the Base bracket beside the wall. **①**
- b) Place and fix the Bottom plate on the Base bracket. **②**

#### CAUTION

Please fix the Bottom plate using M8\*L25 flange bolts with the Base bracket.

#### NOTICE

Tighten the four(4) M8 flange bolts with a torque of 5N·m (3.7lbf-ft).

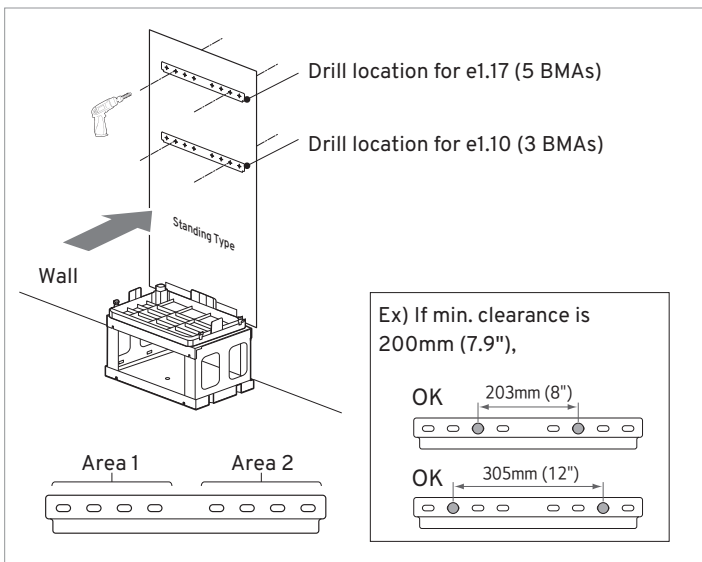

- c) Place the Standing type drill template, check if it is level and drill holes on the position marked on the Drill template.

#### NOTICE

- Recommended fastener count: 1(Area1), 1(Area2)
- Recommended fastener diameter : Min. 10mm (0.4")
- Recommended fastener length: Min. 40mm (1.6")
- The spacing between fasteners should comply with the regional building code.

#### CAUTION

The fasteners for the Standing bracket 1 are not included, so please purchase appropriate fasteners separately. (Standing Bracket part 1 hole : 15mm)

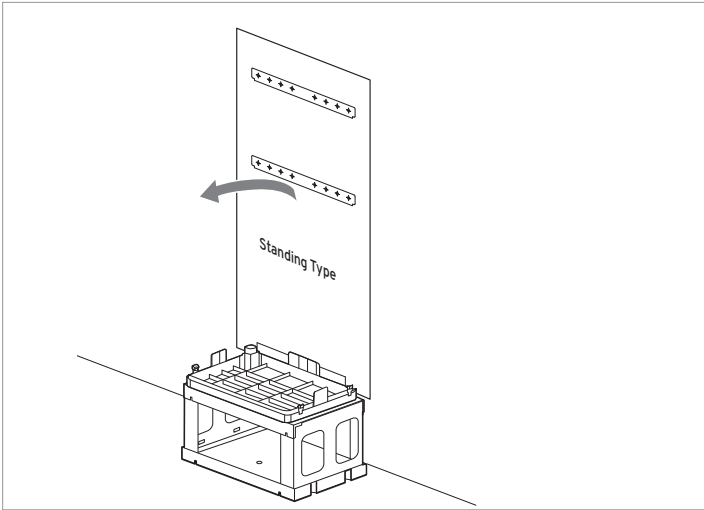

d) Remove the Drill template from the wall.

e) Please follow the 3.1.7.1 (2) - (5).



## 3.2 Cable connections

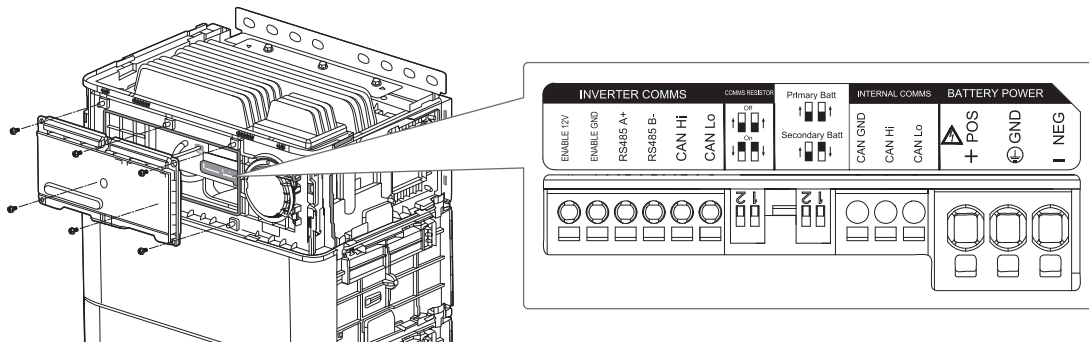

### 3.2.1 Information of cable connection

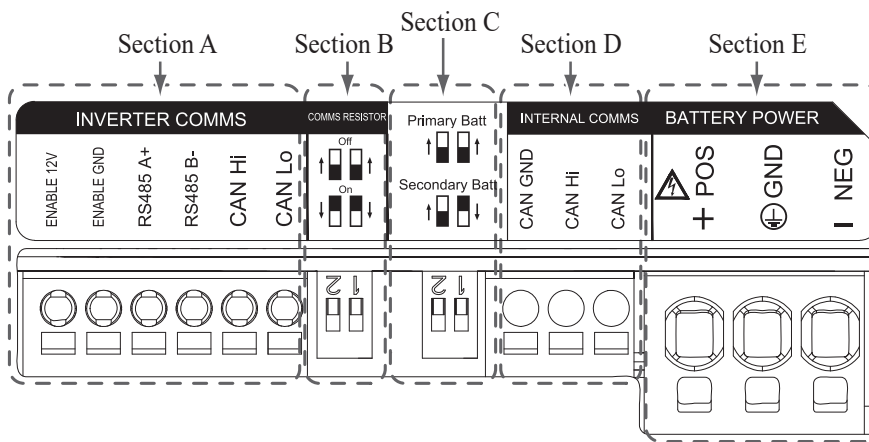

- Section A : Inverter communication port including CAN/RS485 and Enable line.
- Section B : Dip switch for setting communications resistor.
- Section C : Dip switch for setting primary/secondary Battery Packs.
- Section D : Do not connect internal communication port.
- Section E : Battery power port including positive/negative pole and ground.  
(POS: power terminal plus, NEG: power terminal minus, GND: ground)

### 3.2.2 Guide for cable connection and setting the Dip switch

For parallel installation, please refer to Section [6.2 Parallel Installation](#) of this Installation Manual.

#### 3.2.2.1 Section A : Inverter communication port

Max. cable length: 10m (32ft)

Cable type : 0.326~1.646mm<sup>2</sup> (18~22AWG)

- a) Strip each communication cable by 10mm. (0.4")
- b) Crimp ferrules to each cable.

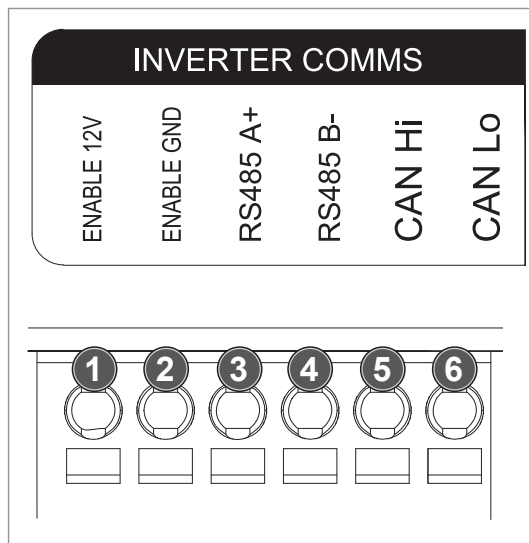

- c) Connect the Enable 12V positive line to terminal. ①
- d) Connect the Enable ground wire to terminal. ②
- e) Select the inverter communication method, CAN or RS485
  - RS485 : Terminal ③ & ④
  - CAN : Terminal ⑤ & ⑥

### 3.2.2.2 Section B&C : Dip switch setting for primary and secondary Battery Packs

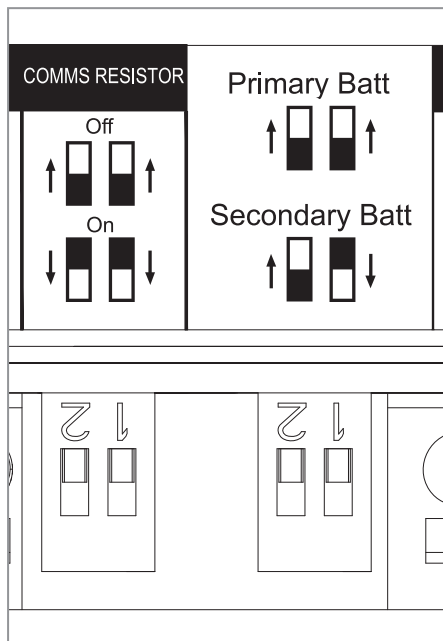

#### Primary Battery Pack

Set the dip switch as shown in the image below.

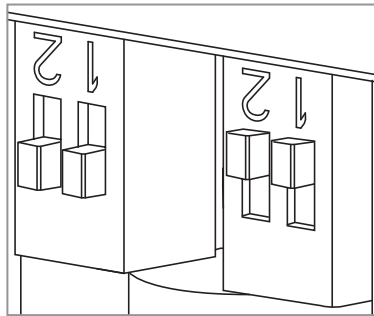

#### Secondary Battery Pack

Set the dip switch as shown in the image below.

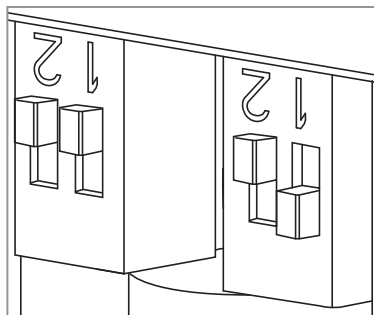

#### NOTICE

When installing a single Battery Pack, set the dip switch as the Primary Battery Pack.

### 3.2.2.3 Section E : Battery power port

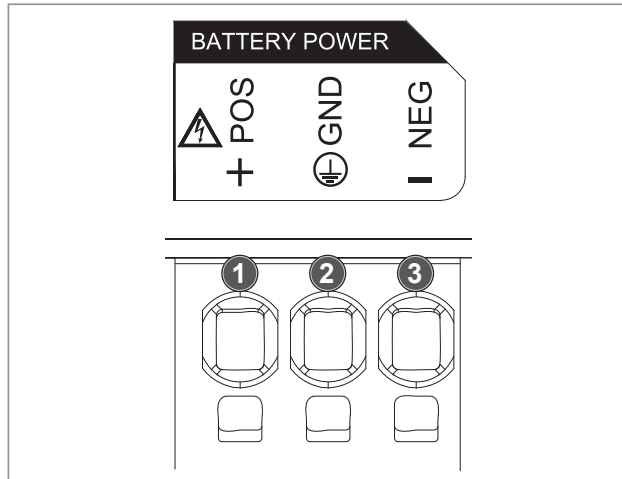

Max. cable length: 10m (32ft)

Cable type : 8mm<sup>2</sup> (8~10AWG)

- a) Strip Power terminal cable by 15mm. (0.6")
- b) Connect the ground wire to terminal. ②
- c) Connect the negative line of the power cable to terminal. ③
- d) Connect the positive line of the power cable to terminal. ①

### 3.3 Uninstallation

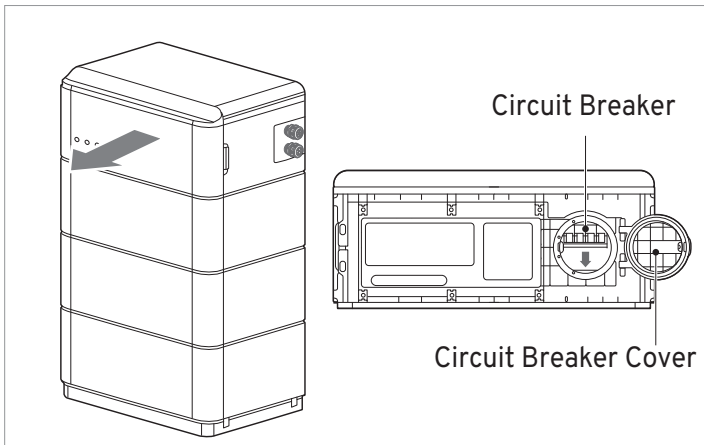

- a) Switch the inverter OFF before beginning uninstallation of the Battery Pack.
- b) Remove the Front Cover of the Battery Pack following the direction of the arrow.
- c) Open the Circuit breaker cover and Turn OFF the circuit breaker. (After 60 seconds, the LED lights will be turned off. It means the Battery Pack has shut down completely.)

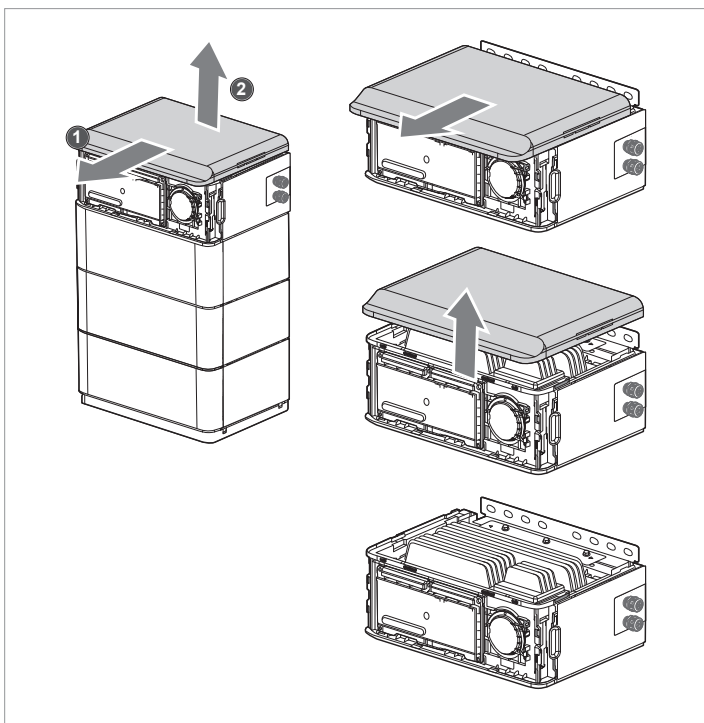

- d) Remove the Top Cover along the direction of arrow 1 and then arrow 2.

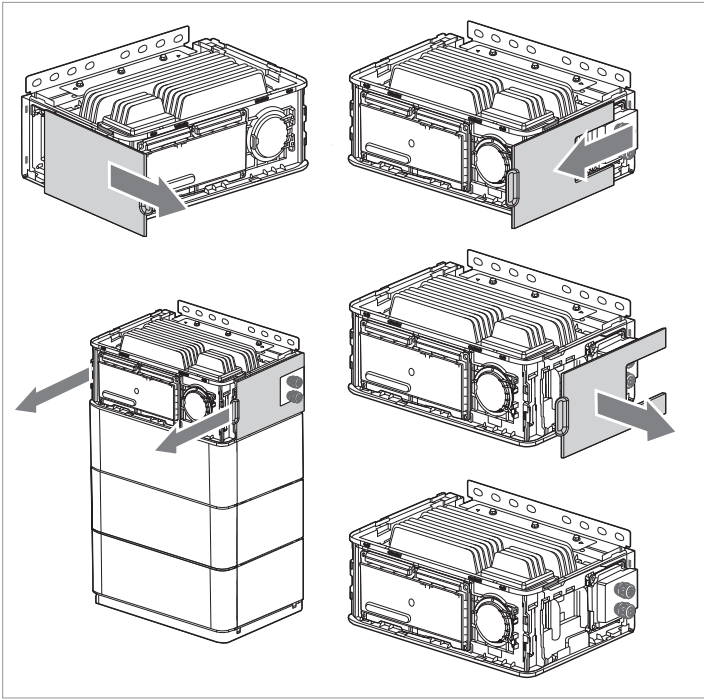

e) Remove the BCU and BMA Side design cover along the direction of the arrow.

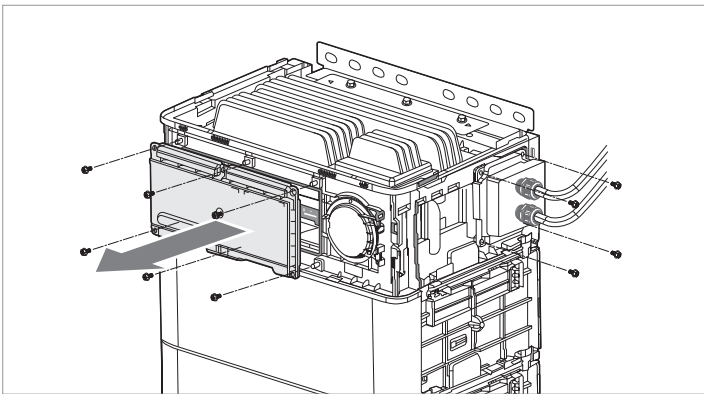

f)-1. Loosen the six(6) M6 Nuts and disassemble the Protection Cover along the direction of the arrow.

f)-2. Loosen the four(4) M6 Nuts and disassemble the Side Sealing Cover along the direction of the arrow.

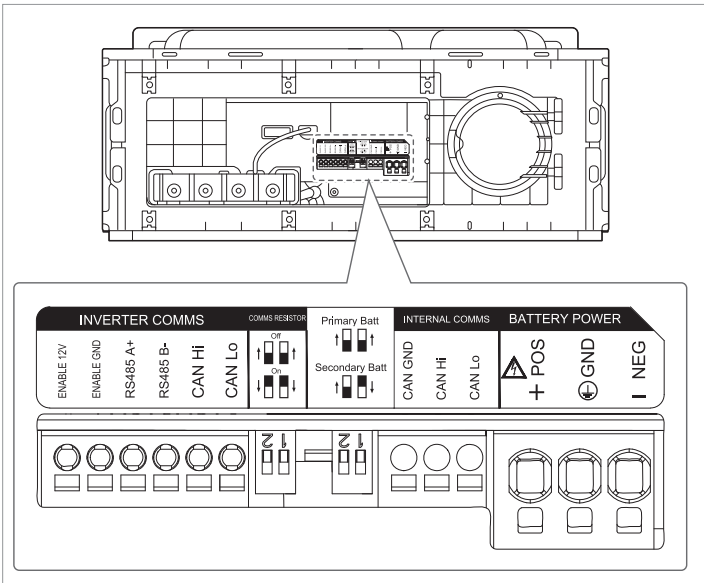

g) Disconnect the enable cable, the communication cable and the power cable from the terminal connector.

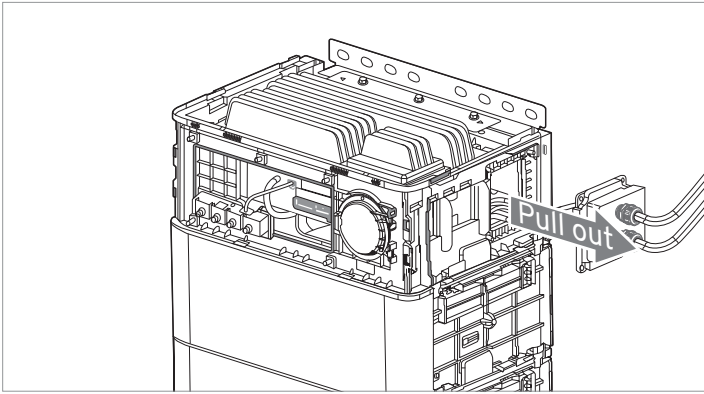

h) Pull out the side sealing cover and cables along the direction of the arrow.

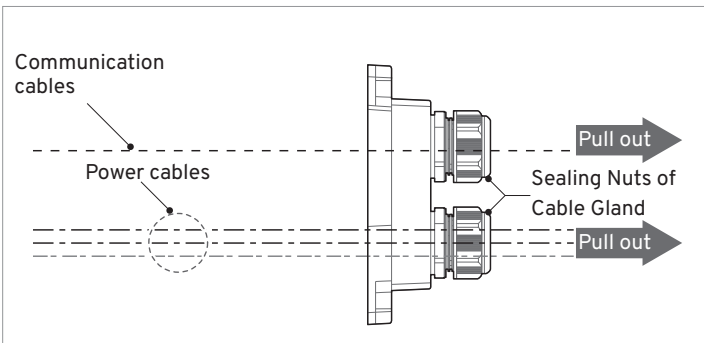

i) After loosening the sealing nut of the cable glands, disassemble the cable from the cable glands.

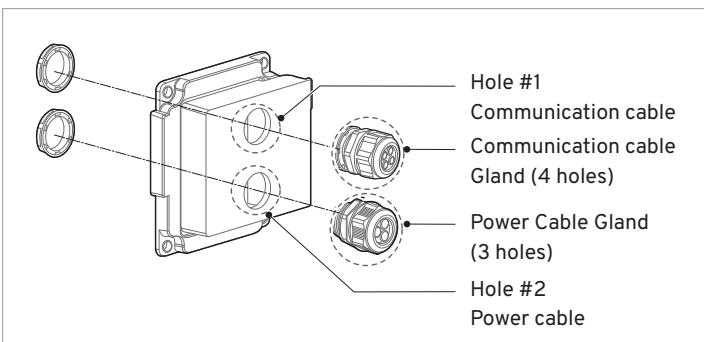

j) Disassemble the Glands from the Side Sealing Cover, and then assemble the Gland components together.

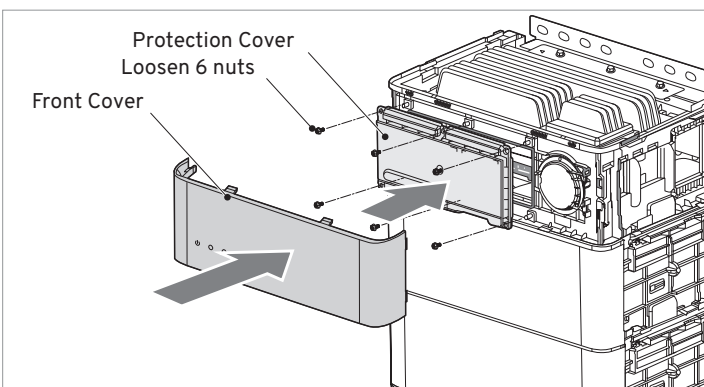

k) Reassemble the Front Cover and the Protection Cover.

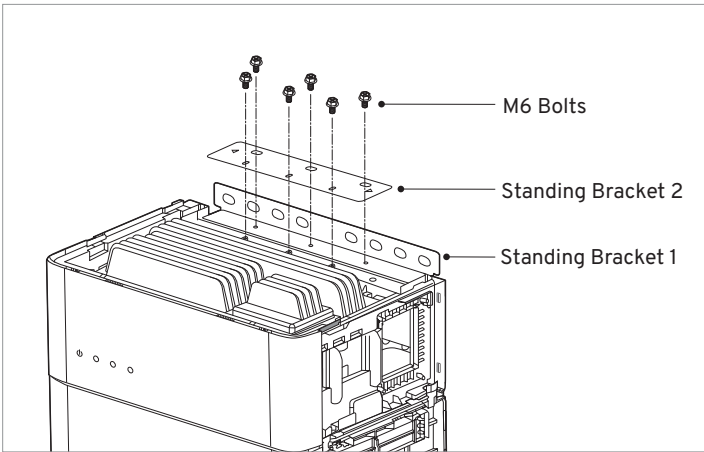

l) Loosen six(6) M6 SEMS bolts and disassemble the Standing Bracket 1, 2.

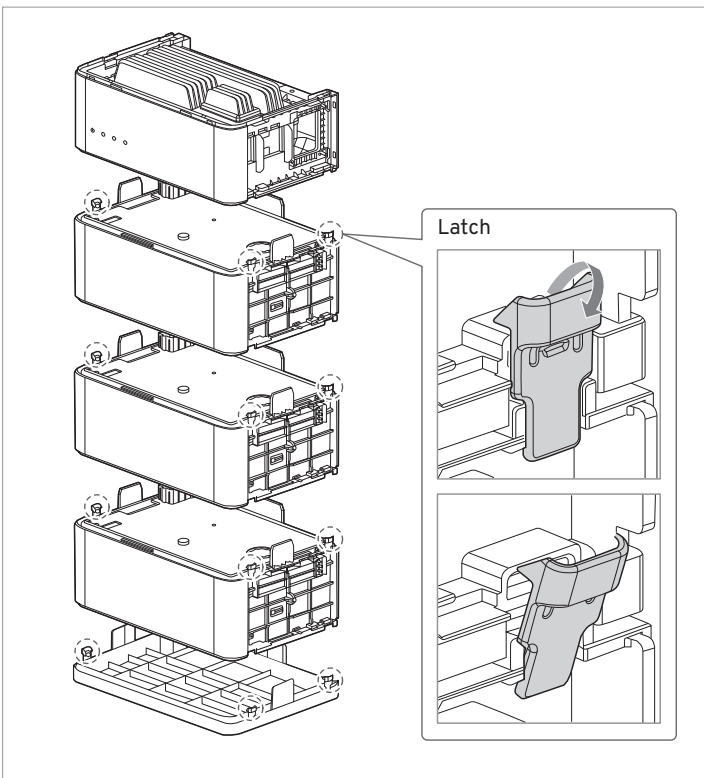

m) Disassemble and repack BCU and BMAs.



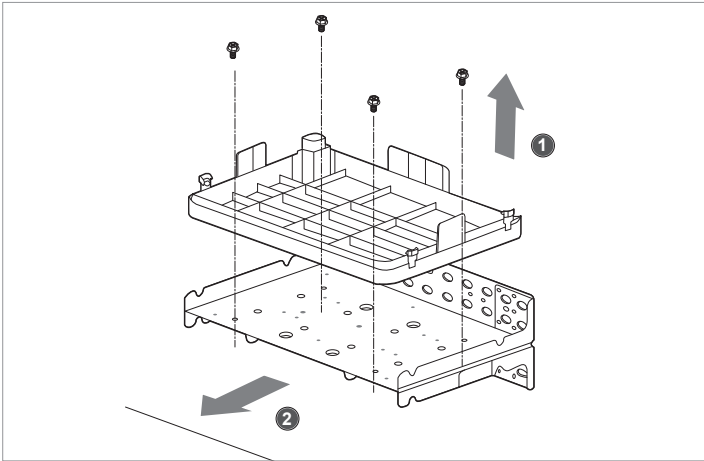

n) (Wall Mounting Bracket/Base Bracket Type only) Loosen four(4) M8 Flange bolts and disassemble the Bottom Plate. Then remove the Base/Wall Mounting Bracket.

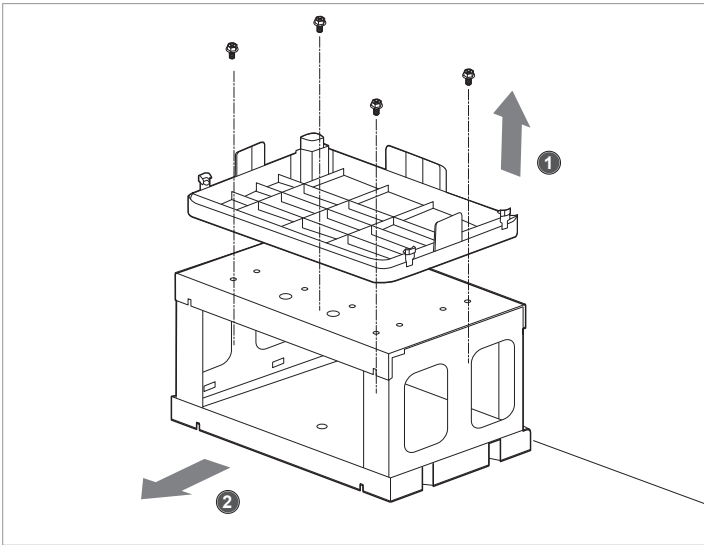

# 4 Commissioning

## 4.1 LED indicators

The LED indicators on the front of the BCU show each status.

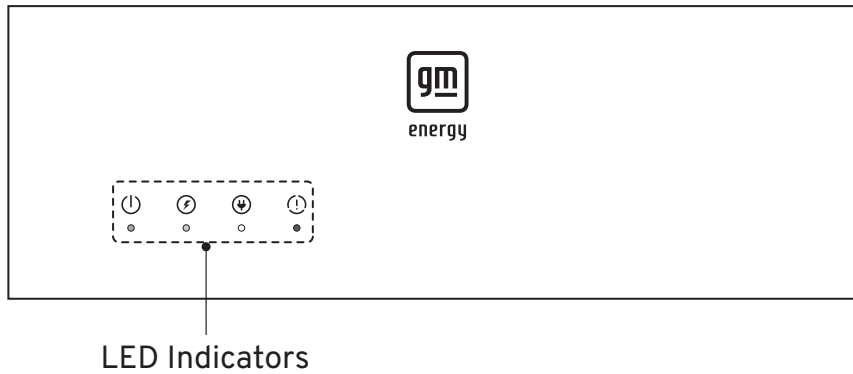

LED 1 (Power)	LED 2 (Charge)	LED 3 (Discharge)	LED 4 (Fault)	Status	
				Power on (Max. 14 seconds)	
				Ready	Normal
				Charge	
				Discharge	
				Fault 1	
				Fault 2	
				Power-saving (Every 10s)	
				Updating (Every 1s)	FW Update
				Update Complete	
				Update Failed	

## 4.2 Powering up the Battery Pack

Power on the Battery Pack by following the steps below:

1. Open the front cover and the circuit breaker cover.  
(refer to Section [3.1.7.1 \(5\)](#) of this Installation Manual)
2. Make sure that the circuit breaker located on the Battery Pack switch is in the OFF position.
3. Turn on the circuit breaker located on the Battery Pack.
4. When the circuit breaker switch is ON, the 4 LED indicators will light up.
5. After the battery has been successfully initialized, the LED 1 (power) will be green and LED 2~4 will be off.
6. Close the circuit breaker cover and the front cover.
7. Turn on the inverter.

### CAUTION

If the LED lights stay OFF, this indicates fault or a failure to operate, do not use the Battery Pack system and contact your installation provider or GM Energy.

## 4.3 Shutting off the Battery Pack

Shut off the Battery Pack according to the following steps:

1. Turn off the inverter.
2. Open the front cover and circuit breaker cover located on the Battery Pack.
3. Turn off the Battery Pack by moving the circuit breaker switch to the OFF position.
4. Make sure that every LED indicator on the Battery Pack is off. (After 60 seconds, the LED lights will be turned off. It means the Battery Pack has shut down completely.)
5. Close the circuit breaker cover and the front cover.

# 5 Troubleshooting

Check the LED indicators on the front to determine the state of the Battery Pack . A warning state is triggered when a condition, such as with voltage or temperature, is beyond design limitations. The Battery Pack’s BMS periodically reports its operating state to the inverter.

When the Battery Pack falls outside prescribed limits, it enters a warning state. When a warning is reported, the inverter may immediately stop operation.

The warning state is cleared when the Battery Pack recovers normal operation. If the Battery Pack is not working correctly and the issue persists, contact a qualified personnel, Installer or GM Energy Support Center for assistance.

## NOTICE

The Battery Pack's circuit breaker will trip automatically to protect itself if the inverter does not take proper corrective actions due to an error or fault.

### 5.1 Post-Installation Check List

	Yes	No
1. Visual check if the wiring matches with the instructions set out in Section <a href="#">3.2 Cable connections</a> of this Installation Manual.	<input type="radio"/>	<input type="radio"/>
2. The Circuit Breaker located on the Battery Pack is ON.	<input type="radio"/>	<input type="radio"/>
3. The Battery Pack’s LED power indicator is ON.	<input type="radio"/>	<input type="radio"/>
4. The inverter power is ON.	<input type="radio"/>	<input type="radio"/>
5. The inverter recognizes the Battery Pack. <sup>1)</sup>	<input type="radio"/>	<input type="radio"/>
6. The Battery Pack is operational after installation.	<input type="radio"/>	<input type="radio"/>
6-1. The AC grid is connected.	<input type="radio"/>	<input type="radio"/>
6-2. The Meter is installed.	<input type="radio"/>	<input type="radio"/>
6-3. Government approval is complete.	<input type="radio"/>	<input type="radio"/>
7. The inverter and the battery both have the latest firmware installed. <sup>2)</sup>	<input type="radio"/>	<input type="radio"/>
8. Commissioning of the system is completed by following the inverter manufacturer’s installation guide.	<input type="radio"/>	<input type="radio"/>
9. IF ANY ITEM IN #6 IS CHECKED AS “NO” OR THE INVERTER NEEDS TO BE TURNED OFF, TURN OFF THE CIRCUIT BREAKER. <sup>3)</sup>	<input type="radio"/>	<input type="radio"/>

1) Refer to the inverter installation manual or troubleshooting guideline.

2) Contact the inverter manufacturer.

3) Please refer to the Installation manual ([3.3 Uninstallation](#)) for the location of the circuit breaker of the Battery Pack.

## 5.2 Troubleshooting Guidelines

### If the Battery Pack's "Power on" LED indicator is OFF

1. Turn off the Circuit Breaker located on the Battery Pack.
  2. Turn off the inverter. Verify there is no power at the Battery Pack connection.
  3. Unplug all the wires and reconnect. Re-check the wiring on the Battery Pack is done correctly. Refer to 3.2 Cable connections.
  4. Turn on the Circuit Breaker located on the Battery Pack.
  5. Turn on the inverter.
  6. If the "Power on" LED indicator located on the Battery Pack is still off, turn off the Circuit Breaker located on the Battery Pack.
  7. Turn off the inverter.
  8. Disconnect the power cable connector.
  9. Contact GM Energy Support Center for assistance.
- 

### If the Battery Pack's "Power on" LED is ON, but the Battery Pack is not charging or discharging

1. Update both the inverter and Battery Pack firmwar. Refer to the inverter's troubleshooting guide for instruction.
2. Check the inverter's setting for battery. Refer to the inverter's troubleshooting guide for the Battery Pack set-up instruction.
3. If the Battery Pack is recognized, inverter set up is correct.
4. If the issue persists,
  - 4-1. Turn off the Circuit Breaker located on the Battery Pack.
  - 4-2. Turn off the inverter. Verify there is no power at the Battery Pack connection.
  - 4-3. Unplug all the wires and reconnect. Re-check the wiring on the Battery Pack is done correctly. Refer to Section [3.2 Cable connections](#) of this Installation Manual.
  - 4-4. Turn on the Circuit Breaker located on the Battery Pack.
5. If the battery set up is correctly done, but if the Battery Pack still does not operate, turn off the Circuit Breaker located on the Battery Pack.
6. Turn off the inverter
7. Contact GM Energy Support Center for assistance.

**If the Battery Pack's FAULT LED indicator is ON**

1. Check if the inverter recognizes the Battery Pack. Refer to the inverter's troubleshooting guide on the Battery Pack set-up instruction.
2. If the inverter is connected to the internet, collect the log file from the inverter company.
  - 2-1. Send the fault ID to GM Energy Support Center.
  - 2-2. Turn off the Circuit Breaker located on the Battery Pack.
  - 2-3. Wait further instruction from GM Energy.
3. If the inverter is not connected to the internet, check the inverter LCD to read Battery Pack's fault ID. Refer to the inverter's troubleshooting guide for instruction.
  - 3-1. Send the fault ID to GM Energy Support Center.
  - 3-2. Turn off the Circuit Breaker located on the Battery Pack.
  - 3-3. Wait further instruction from GM Energy.

# 6 Appendix

## 6.1 Single Pack Installation

When installing a single Battery Pack, set the dip switch as shown in the Primary Battery Pack image below.

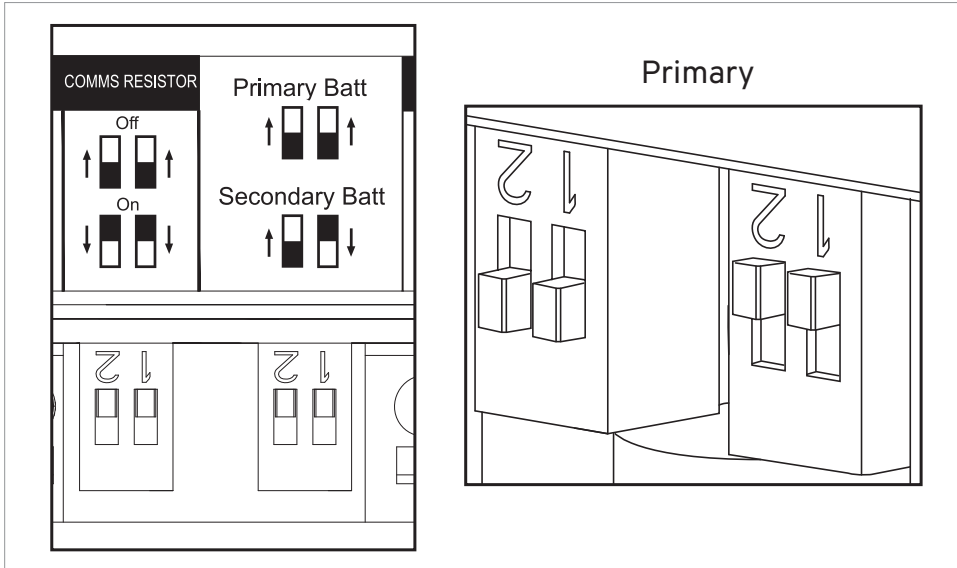

## 6.2 Parallel Installation

### CAUTION

※ Parallel installation is allowed only with two of the same GM Energy PowerBank series.

### 6.2.1 Communication port

#### 6.2.1.1 When inverter has only one communication ports (RS485)

When you install two batteries in parallel and the inverter has only one communication port, communication cables should be connected by a daisy chain. Communication line from the inverter should be connected to the secondary Battery Pack first and then the additional communication line is connected from the secondary Battery Pack to the primary Battery Pack as shown in the below chain configuration. If the batteries are installed with incorrect configuration, the Battery Pack will not operate properly. In other case, communication lines can also be connected through the combiner box.

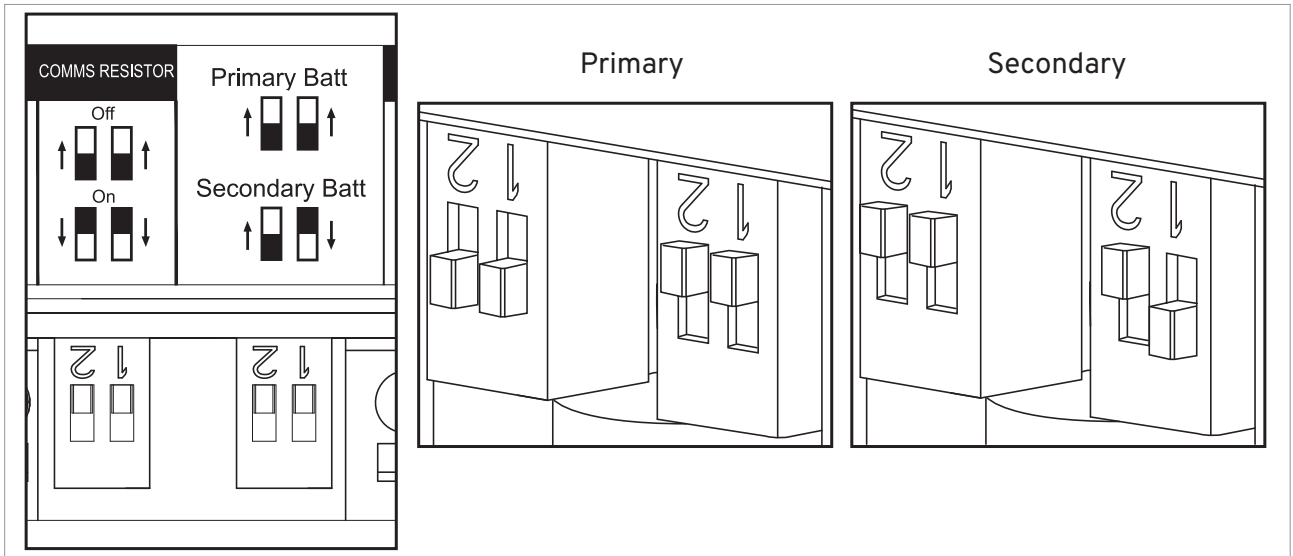
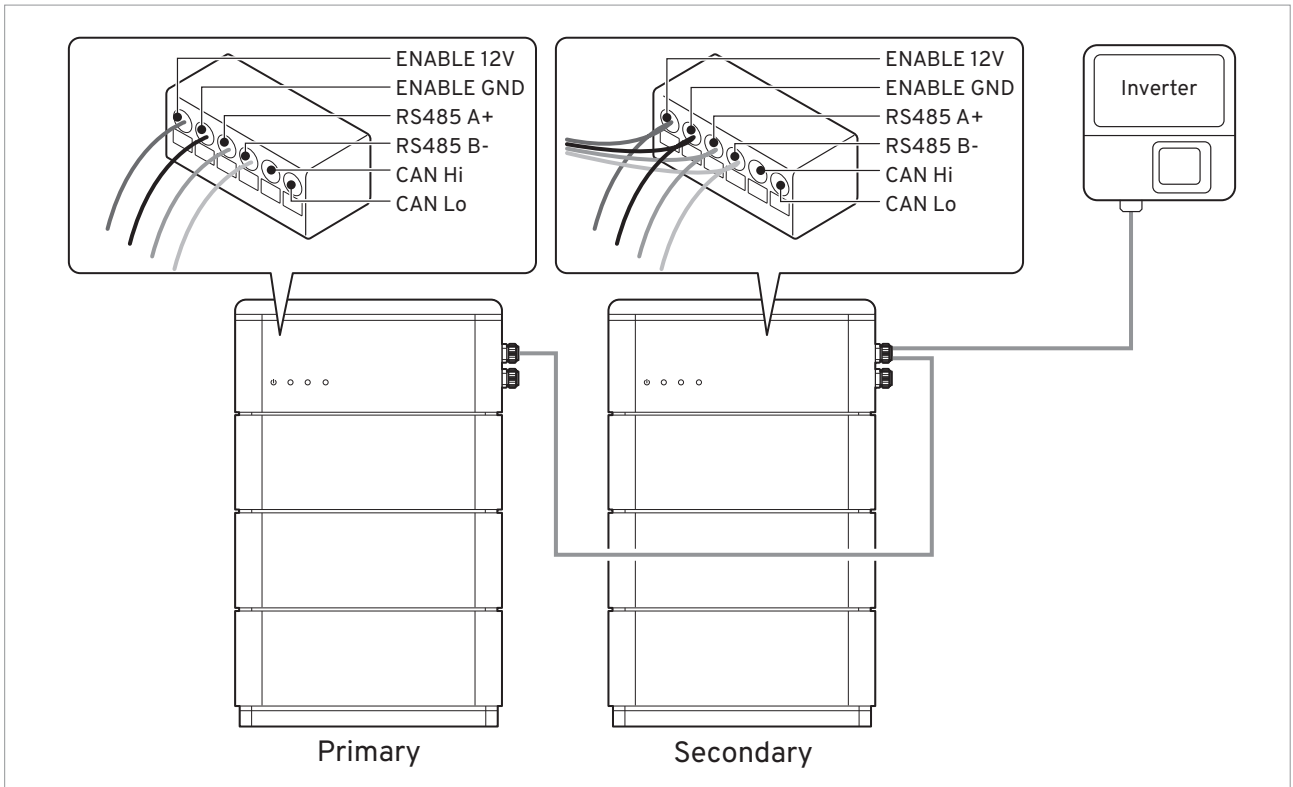



## 6.2.2 Power port

### 6.2.2.1 Examples of parallel power cable connection



#### WARNING

When connecting Battery Pack's power lines in parallel, it is important to use a device that matches the electrical specifications of the product.

Refer to section [2.1.1 Specification](#) to select a product that meets the electrical specifications of this Battery Pack product.

To connect two Battery Packs and an inverter using a combiner box, follow these steps:

1. **Location Setup:** Determine the installation location for the Battery Packs, inverter, and combiner box. Ensure that the batteries and inverter are securely placed and provide adequate space for electrical connections.
2. **Battery Connection:** Connect each power line from each Battery Pack to the combiner box. Pay attention to the polarity of the Battery Packs and ensure they are connected with the correct connections.
3. **Inverter Connection:** Connect the combiner box to the inverter. Double-check the polarity and ensure the correct polarity connection.
4. **Connection Verification:** After the connections are completed, verify the connection status of each cable. All cable connections shall be securely fastened. Electrical safety shall be ensured.

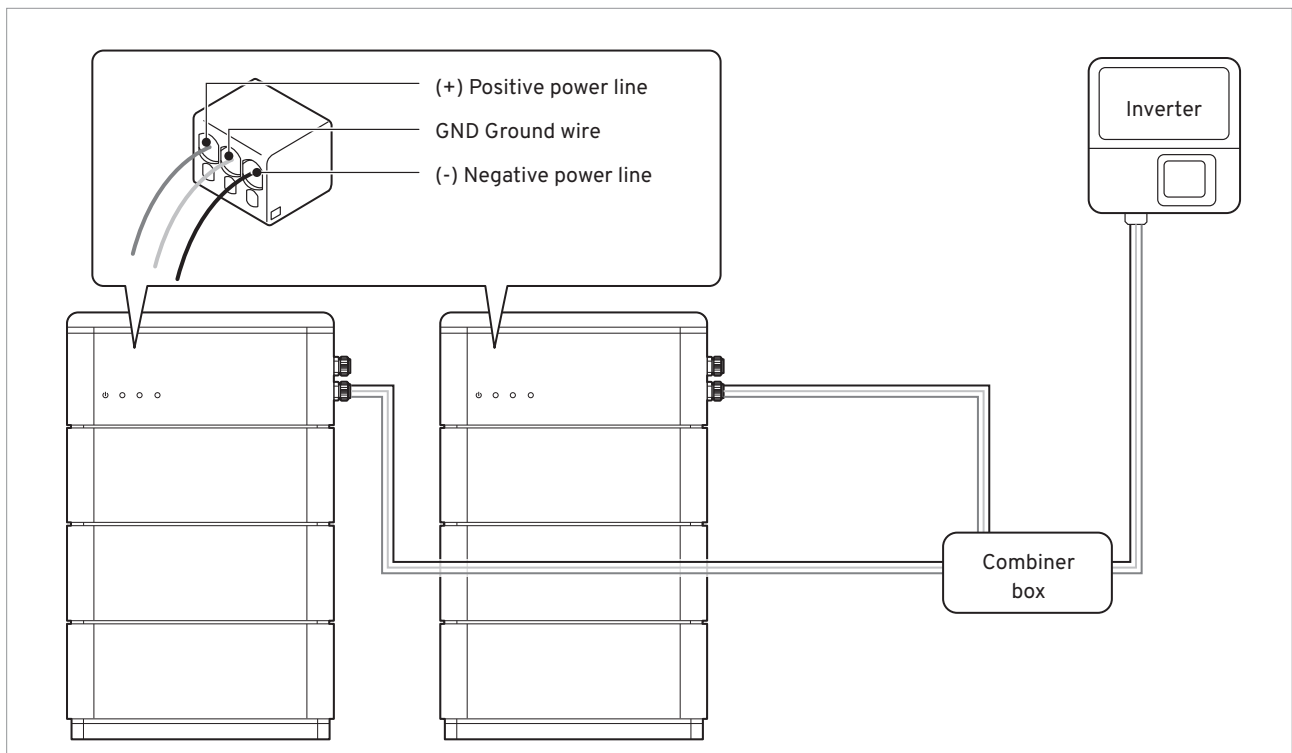

An example of parallel connection with combiner box

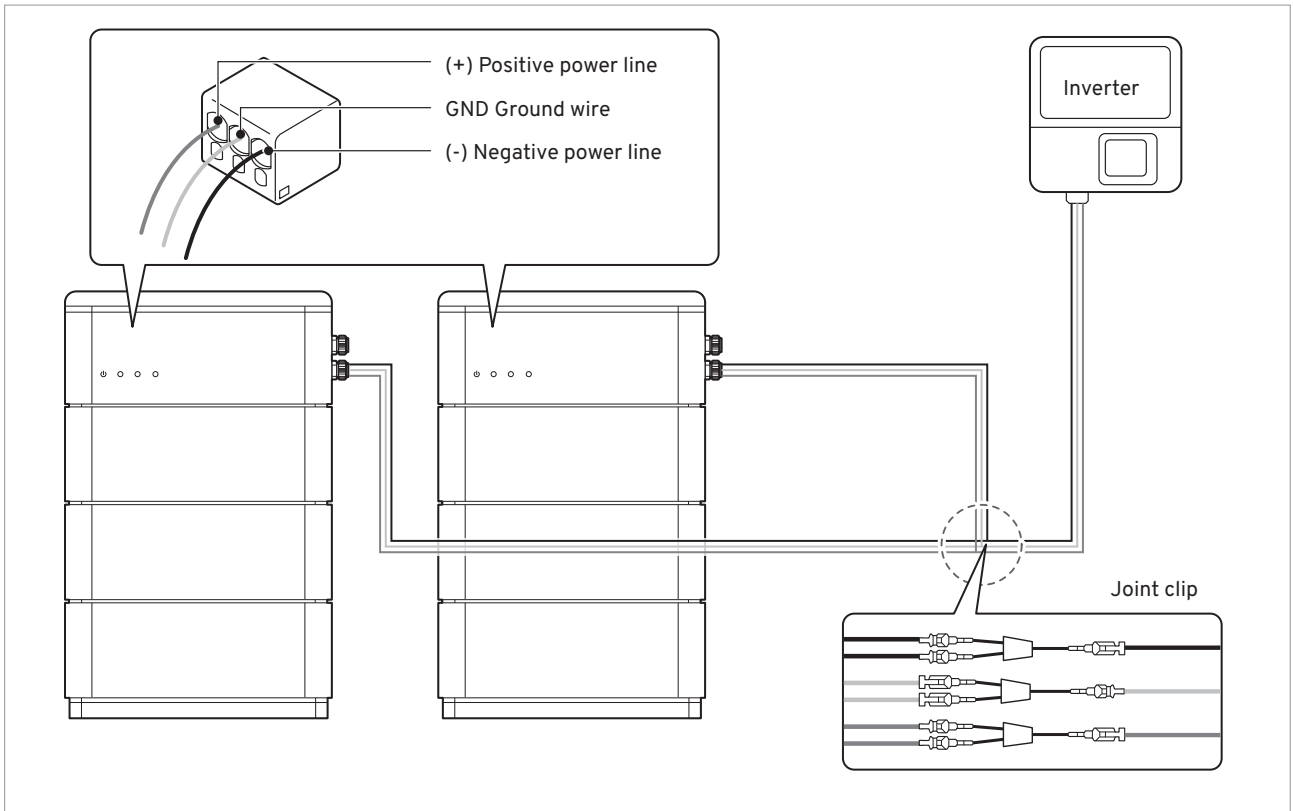

An example of parallel connection with joint clip

## 7 Contact information

Damaged batteries are dangerous and must be handled with extreme caution. They are not fit for use and may pose a danger to people or property. If the Battery Pack seems to be damaged, do not proceed with installation and contact GM Energy Support Center or your distributor.

Use the contacts below for technical assistance. The business hours are Monday - Friday 8AM EST to 12 AM EST and Saturday - Sunday 12PM EST to 9PM EST.

---

<b>Service Contact</b>	
Email	energyservice@gm.com
Phone number	1-833-64POWER

---

Scan the QR code or visit the website below for all product information (installation manuals, user manuals, warranty information, etc)

<https://gmenergy.gm.com/home/resources-and-support>

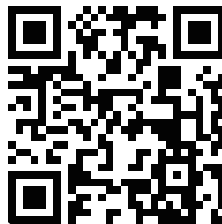



V1.0



PowerBank